



MODEL YD243

Round Single Wing Fusible Link Fire Damper

Project:
Tag:
Engineer:
Contractor:
Date:

WITH FLANGE

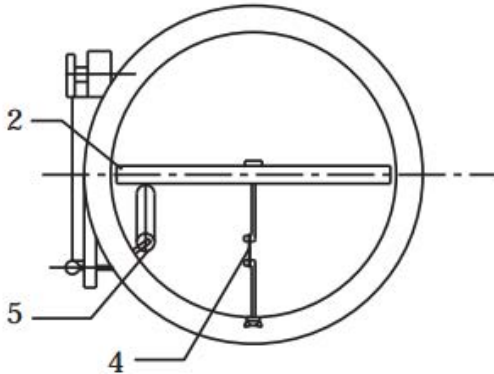

WITHOUT FLANGE

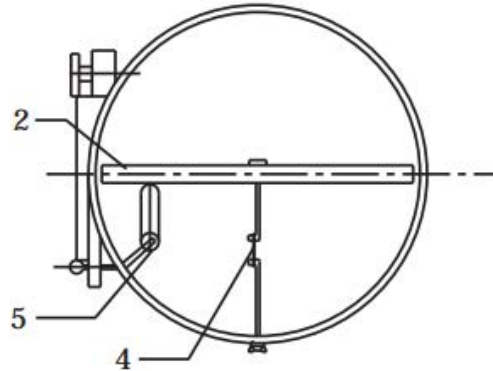

- 1- Chassis
- 2- Damper Blade
- 3- Manual Lever
- 4- Thermal Release (fusible link 72°C)
- 5- Tension Spring
- 6- Mechanical Interlock
- 7- Tensioning Nut
- 8- Electrical Cut-Out Switch (on request)

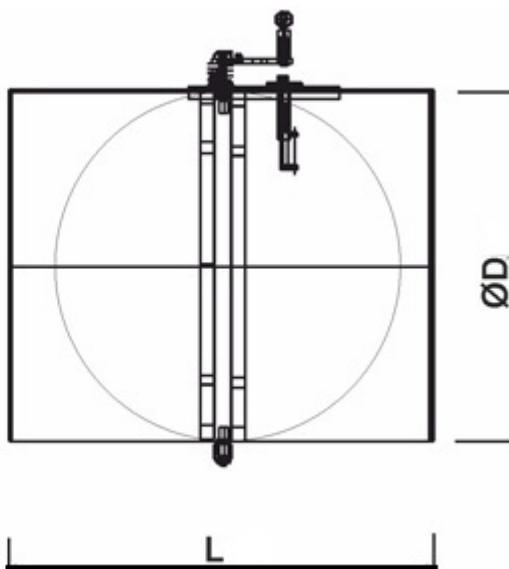
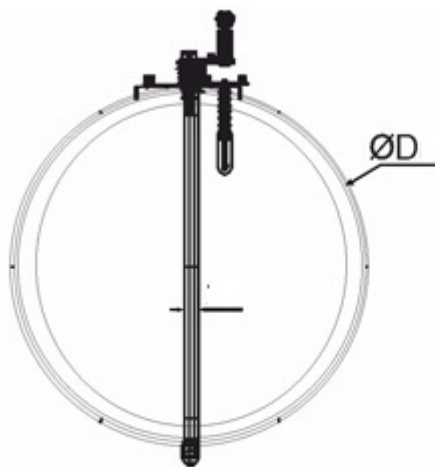

As part of our continuous improvement program, we reserve the right to make further improvements without notice.

			Date submitted:
--	--	--	-----------------