

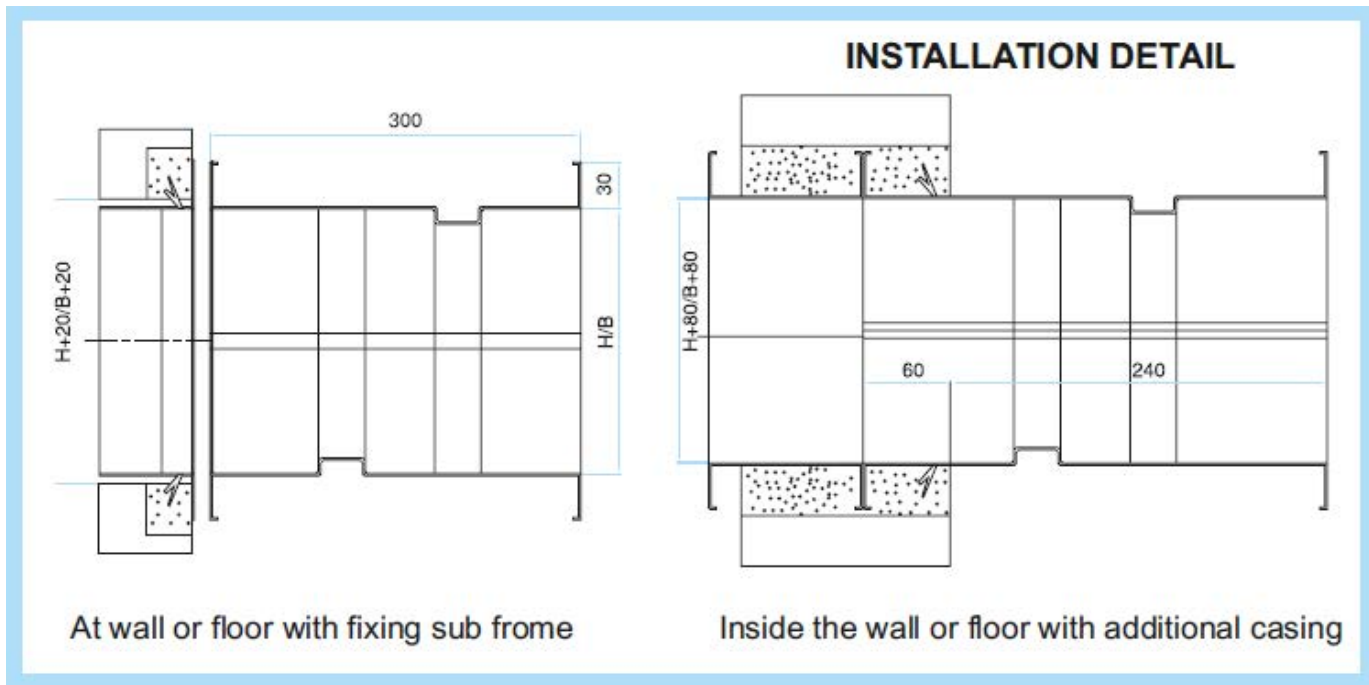

MODEL YD143

Prismatic Single Wing Fusible Link Fire Damper

| |
|-------------|
| Project: |
| Tag: |
| Engineer: |
| Contractor: |
| Date: |

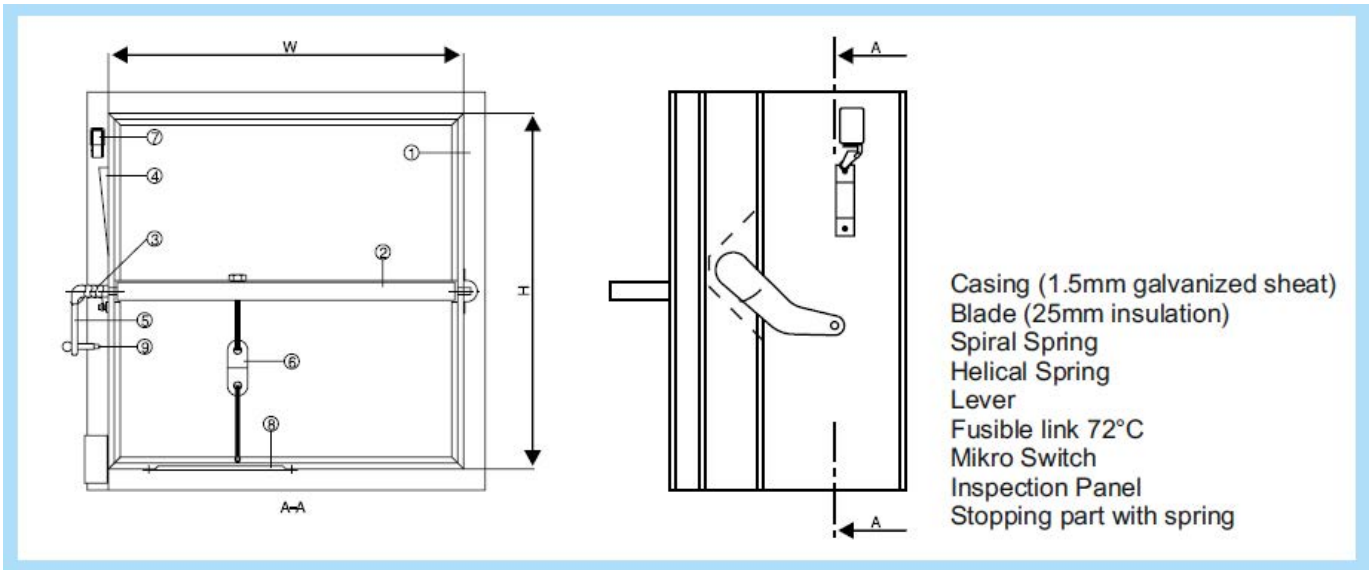

As part of our continuous improvement program, we reserve the right to make further improvements without notice.

Date submitted: