

# DOUBLE INLET CABINET FANS

ENERGY EFFICIENT  
LONG LIFE

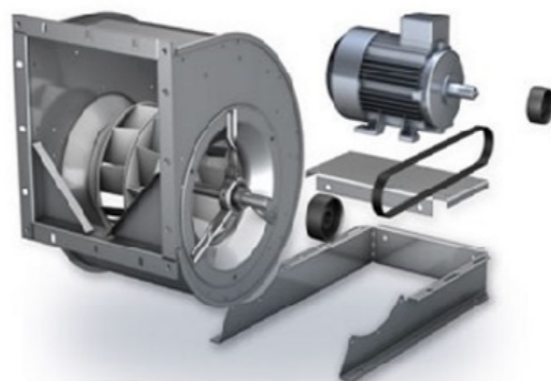

## PRODUCT FEATURES

- Acoustic-Thermal insulated
- Belt driven
- Easy maintenance
- Double suctioned cabined fans can be manufactured as backwarded or forwarded impeller. Double inlet cabinet fans are usually used for commercial and industrial areas for extraction or fresh air supply in ambience
- Double inlet cabinet fans have different angular design for purpose and place usage
- Motor bearing is maintenance-free and long lived. In addition to that, all the dimensional tolerances of the fan shafts are fully controlled to provide precise mounting

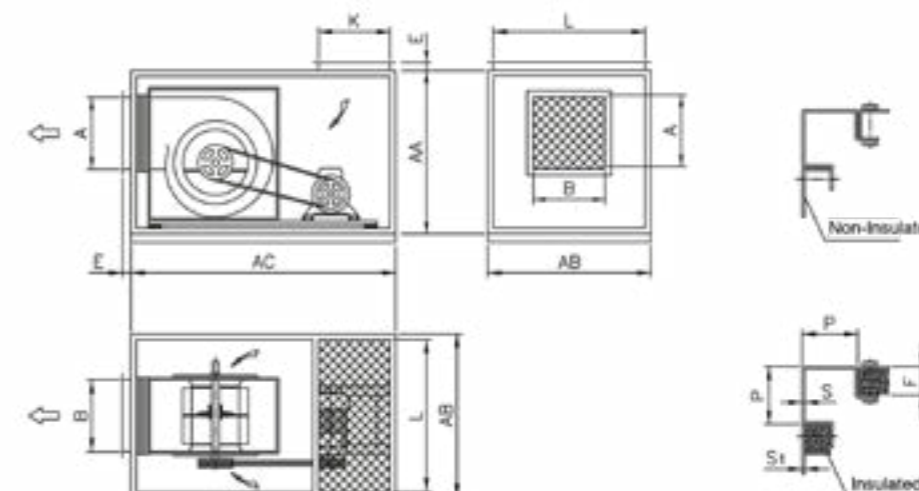

## TECHNICS

MODEL	Min.kW	Max.kW	Min. m <sup>3</sup> /h	Max. m <sup>3</sup> /h	Min. d/d	Max. d/d
GECO-S-180	0,1	1,1	140	3500	850	1910
GECO-S-200	0,126	2	180	5000	765	1910
GECO-S-225	0,16	4	200	7000	680	1900
GECO-S-250	0,2	5	200	9000	610	1710
GECO-S-280	0,25	6,3	200	12000	545	1530
GECO-S-315	0,32	8	400	15000	485	1360
GECO-S-350	0,4	10	500	19000	430	1205

## DIMENSIONS

Product Code	Common			A	B	K	L	P	S	E	F	S1
	AA	AB	AC									
	mm	mm	mm	mm	mm	mm	mm	mm	mm	mm	mm	mm
GECO-S-180	560	560	710	224	224	224	480	40	1.5	60	20	1
GECO-S-200	630	630	800	250	250	250	530	50	2	60	20	1
GECO-S-225	70	710	900	280	280	280	610	50	2	60	20	1
GECO-S-250	800	800	1000	315	315	315	700	50	2	60	20	1
GECO-S-280	800	800	1120	355	355	355	700	50	2	60	20	1
GECO-S-315	900	900	1250	400	400	400	780	60	2	80	30	1.2
GECO-S-350	1000	1000	1250	450	450	450	880	60	2	80	30	1.2

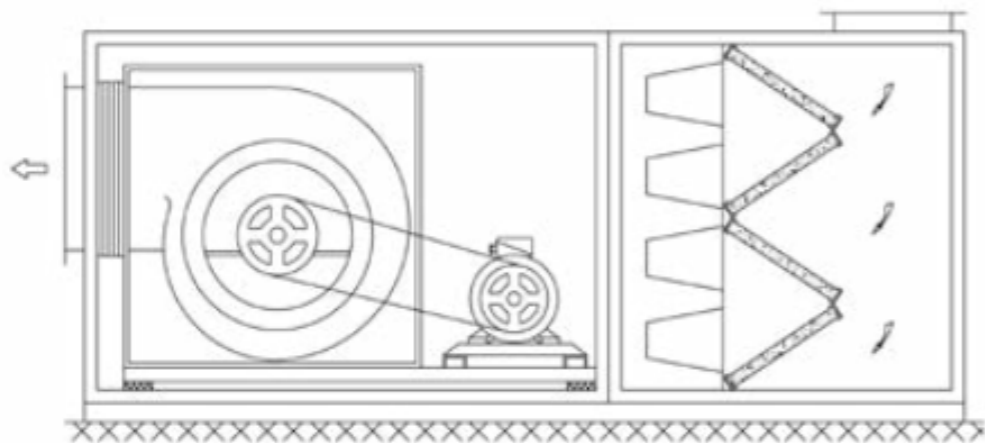
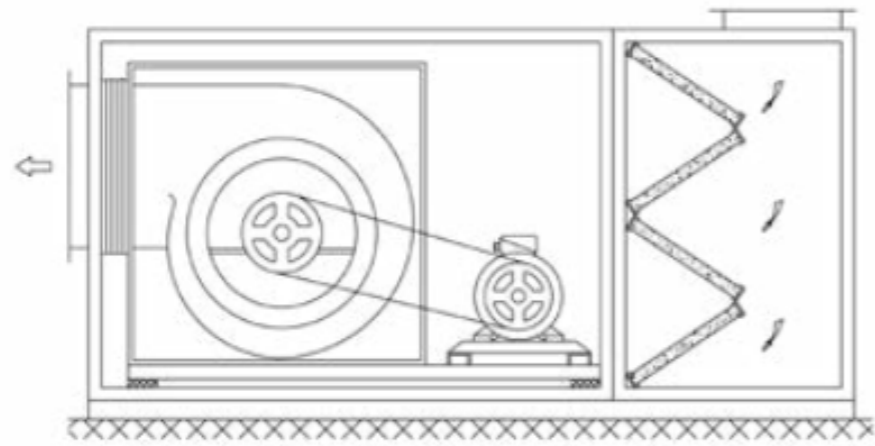

1A	2A	3A	4A
1A1	2A1	3A1	4A1
1B	2B	3B	4B
1B1	2B1	3B1	4B1
1C	2C	3C	4C
1C1	2C1	3C1	4C1
1D	2D	3D	4D
1D1	2D1	3D1	4D1