



# GCR

**Air Handling Units with  
Rotary Heat Recovery**

[www.gmcair.com](http://www.gmcair.com)



## Casing Structure

Specially drawn aluminum profiles for air handling units with 50mm panel thickness, roll-formed steel profiles for air handling units with 60mm panel thickness, intermediate profiles and panels are used in the "Gmcair" air handling unit. Aluminum and steel profiles are electrostatic powder painted. The profiles are connected with specially-designed plastic corners.

The panels are produced in standard dimensions and as double skin. Rock-wool, glass-wool or polyurethane is used inside the panels as insulation material. The thickness of the panel is 50 mm or 60 mm. The outer skin of the panels is painted to RAL 9002 color as standard and is coated with protective film whereas the inner skin is made from galvanized, stainless or painted steel plates. The thickness of the plate is 0,8 to 1,2 mm. The panels can be dismantled outside the unit. The unit is designed to have a completely smooth internal surface. The panels are directly connected to the profiles with self-drilling screws. EPDM-based sealing gaskets are used between the panels and profiles. Intermediate profiles are used between panels. The intermediate profiles are also filled with insulation material.

Air tight service doors are mounted where necessary on the unit. Service doors can be produced to have inspection window depending on demand and intended use [hygienic, etc.].

The base of the unit can be produced as a single part or to have multiple cell-based parts according to the size of the unit. Air handling units with drain pan [for example unit with cooling coil] are placed on 200 mm high base frame and other units 80 or 100mm high base frame as standard. There are holes on the base frame for lifting intended for easy transport.

For the outdoor units, there are special roofs designed to protect the unit from outdoor weather conditions.

The air handling unit can be transported as sections or as completely dismantled for easy transportation and it can be re-assembled on site. Special connection elements are used to connect the sections on site. Special EPDM seals are used to provide air tightness between sections.

## Accessories

Accessories such as lighting, inspection window, manometer, flexible connection at discharge and suction openings, siphon, repair switch, damper motor and rain protection are available at Four Season air handling units on request.

## Filters

Whole cross section of Four Season air handling units are used as filtering area in compliance with international standard filter dimensions. The filters are easily mountable and dismountable. Air leakage is prevented thanks to optimal design. There is a service door located on the filter cells for maintenance and replacement. There are optional manometer, lighting and inspection window.

Considering indoor air quality in air handling units, there are different types of filters coming in different efficiency levels. Typically, these are panel filter, bag filter, metal filter, active carbon-filter, compact filter and hepa filter.

Panel filters are used as pre-filters. The material of the filter is synthetic or metallic. Metal filters can retain oil. The classes of the filters we use are G2, G3 and G4 for synthetic filters and G2 and G3 for metallic filters.

Bag filters are used for highly-efficient air filtration. Their dust holding capacity is quite high. They should be used together with a pre-filter to extend their service life. The bag length range is 360 mm, 500 mm and 600 mm depending on the air volume. The classes of the filters we use are G4, M5, M6, F7 and F8.

Compact filters are highly-efficient filters. They should be used together with a pre-filter. Since their depth is 292 mm, these filters occupy a little space in the unit. It is possible to equally distribute the air on the whole surface of the filter due to the structure of the filter. The classes of the filters we use are M6, F7, F8, and F9

Hepa filters should be preferred for hygienic environments. They are very high efficiency filters. These filters are assembled after the ventilator and should absolutely be used along with a pre-filter. The classes of the filters we use are H13 and H14.

Active carbon-filters are used to suction the molecules of foul gasses or vapors in the air [exhaust fumes, rubber odor, alcohol, hydrocarbon, chlorine and other odors dispersed from chemical production processes]. There is an alternative model designed for the suction of odors such as hydrogen sulfite and sulfur dioxide dispersed from other industrial processes. They should be used along with a pre-filter to extend their service life.

## Inlet – Mixing – Outlet Sections

### Dampers

The damper sections are sized according to the air velocity. As a standard, airfoil type and opposed blade dampers are used. The casing and blades of the damper are aluminum. Air leakage is minimized by means of the seals at the edges of blades. Dampers are produced to be for manual use or with servomotor.

Servomotor, rain hood and flexible connectors can be included optionally.

Damper sizes are standard as per the type of the air handling unit and designed to allow for the passage of 100% air volume.



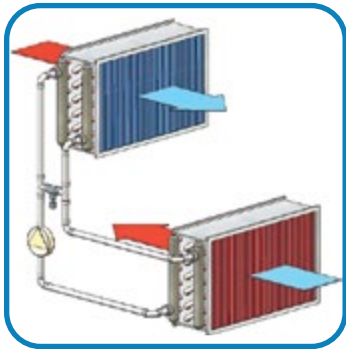

## Heat Recovery System

Today, energy efficiency is an important matter. Therefore, the use of heat recovery systems in air handling units is gradually increasing.

Run around coil type, plate type and rotary type heat recovery systems are used in Gmcair air handling units.

The efficiency generally ranges between 30-50% for run around coil type, 40-60% for plate type and 60-80% for rotary type.

### Run Around Coil Type Heat Recovery

The heat transfer with double-coil type heat recovery is performed by the fluid circulating in the coils of the supply and exhaust units in a closed cycle. The heat is first transferred from air to water and then from water to air. There is no risk of mixing exhaust air to supply air. Ethylene glycol is used in the areas where there is a risk of freezing. There is a need of circulation pump and balance tank for the system. There is a drain pan used on the exhaust side.



### Plate Type Heat Recovery

Cross-flow plate type heat recovery units provide the heat transfer between the fresh air and the exhaust air without moving parts. It can allow for complete tightness even in high pressure differences. It can operate at temperatures ranging between  $-30^{\circ}\text{C}$  and  $90^{\circ}\text{C}$ . The plates are made of aluminum, epoxy-coated aluminum or stainless steel. They are manufactured with by-pass dampers to prevent freezing in low temperatures. A drain pan is used in the exhaust side.

### Rotary Type Heat Recovery

They are compact and have high thermal efficiency. The heat transfer is actualized via the aluminum plates in wavy plate form. The rotation of the rotor is performed by the electric motor with a V- belt drive.

**They can generally be categorized in 3 types:**

#### 1- Condensation rotors:

Standard condensation rotor transfers sensible energy. It is a cost effective solution for heat recovery.

#### 2- Sorption rotors:

Sorption rotor transfers sensible and latent energy. With their special surface coating or surface shape high humidity transfer is achieved. Reduces the cooling capacity by drying and cooling the external air, therefore provides significant amounts of energy savings since low capacity cooling groups are used.

#### 3- Enthalpy rotors:

Enthalpy rotor transfers high sensible and limited latent energy.

Rotor diameter is between 250-5000 mm. It takes little space due to its compact structure. Temperature efficiency of the rotors has been optimized for 12 rpm. Rotation control can be performed with a frequency convertor if capacity control for varying climate conditions is desired. Capacity control request has to be pointed out when placing the order. There is no risk of freezing.



## Determining the Fan Position in Air Handling Units with Rotary Type Heat Recovery

Due to the rotation of the rotor, a part of the exhaust air remains in the rotor. Without a purge zone a certain amount of exhaust air will always be carried over to the supply air. This can be prevented with a correctly dimensioned purge zone. The purge zone is located on the supply air side, after the rotor. According to EN308 and ARI 1060 rate of carryover is maximum 3 %. Amount of carryover on a properly configured and pressurized rotor which is produced with a standard purge zone is 0,5 % and below. Purge zone angle depending on fan positions and pressure difference is indicated on the chart.

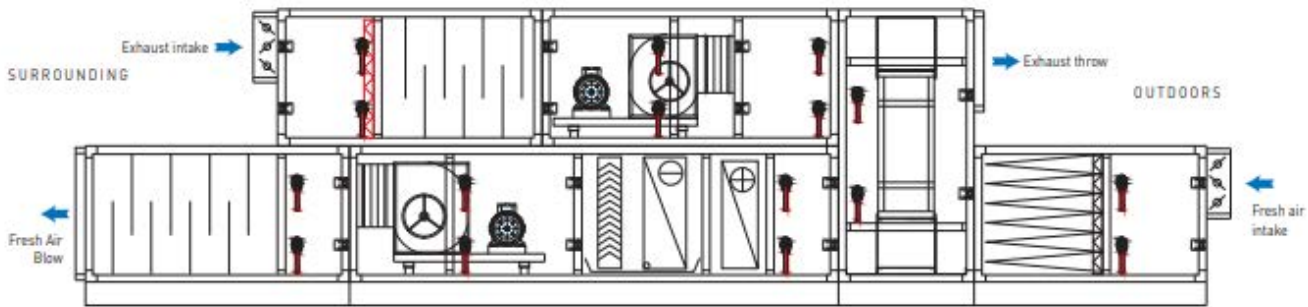
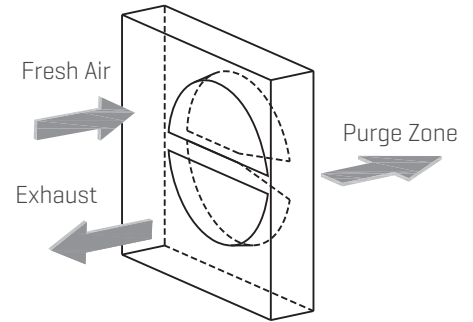

## Fan Position, Pressure Difference and Purge Zone

Fan Position	$\Delta P < 200 \text{ Pa}$	$\Delta P 200\sim 500 \text{ Pa}$	$\Delta P 500\sim 800 \text{ Pa}$	$800 \text{ Pa} < \Delta P$
	Purge Zone Not Required	Purge Zone Standart 5°	2.5°	Purge Zone Not Recommended
	Purge Zone Not Required	Purge Zone Standart 5°	2.5°	Purge Zone Not Recommended
	Purge Zone Not Required	Purge Zone Standart 5°	2.5°	Purge Zone Not Recommended
	Not Recommended			

$\Delta P = P1 - P3$  (Fresh Air and Return Air Pressure Difference)



## Electric Heater

Electric Heater is used optionally on **Gmcair** Air Handling Units. Additionally, it is also used on air handling unit inlets in areas with high risk of freezing.

It is also used on air handling unit outlets of systems which need instant heating.

Electric heater casing is made of galvanized or stainless steel optionally. All components are rustproof material. Protection class is IP43. It can be step or proportional controlled. It holds CE certification. The heaters have automatic-reset limit thermostat and manual-reset safety thermostat as standard.

If the heater is above 30 Kw, the air handling unit's fan is recommended to be kept running for 2-3 more minutes after the power is cut off.

If the air handling unit is equipped with an electric heater, it is a requirement to take precautions to cut-out the electric heater in situations where the fan does not run or runs at very low speeds [below 1,5 m/s].

## Heating and Cooling Coils

Heating and cooling is carried out by coils. Coil pipes can be copper or steel while the fins can be aluminum, copper, steel, epoxy coated aluminum or epoxy coated copper. Direct expansion coils are manufactured as copper pipe-aluminum fins while the collectors are copper.

Coil casing is made of galvanized steel plate. Test pressure for the coils is 20 bars. Pipe inlet-outlet connections on hot and cold water coils are threaded, pipe inlet-outlet connections on high temperature hot water and steam coils are flanged. Coils are mounted on slide rails to be taken out easily for maintenance purposes. The air passes only through the coil surface with the special by-pass plates.

Air and water flow direction is designed as counter flow to obtain high efficiency. Water enters the coil on air leaving side at the bottom and leaves the coil on the air entering side at the top, on hot and cold water coils.

Coil surface has been increased on cooling coils thanks to the special drain pan design. Double slope drain pan is made of stainless steel. After the cooling coil, a droplet eliminator is used to prevent water droplets to be carried with the air.



## Coil Pipe Connection and Service Door Directions



Coil Pipe connection Depending on the Air Flow Direction RIGHT  
Service Door Depending on the Air Flow Direction RIGHT

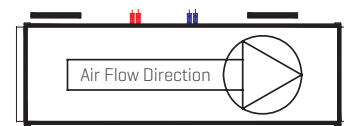

Coil Pipe connection Depending on the Air Flow Direction LEFT  
Service Door Depending on the Air Flow Direction LEFT



Coil Pipe connection Depending on the Air Flow Direction RIGHT  
Service Door Depending on the Air Flow Direction LEFT

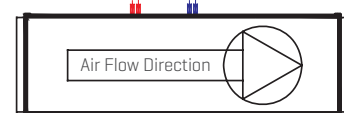

Coil Pipe connection Depending on the Air Flow Direction LEFT  
Service Door Depending on the Air Flow Direction RIGHT

## Steam Humidifiers

The humidifier produces steam from tap water using electrical energy. It is microprocessor controlled. Steam received from the humidifier unit humidifies the air using the steam distribution pipes within the air handling unit. There are many models ranging from 1,5 - 130 kg/h that operate with on-off or proportional controls.

## Evaporative Humidifiers

A circulation pump sends the water on the humidifying media and some of the water is absorbed by the media. As the supply air passes through the media some of the water evaporates on contact with air and humidifies air. The efficiency of the humidifiers that are used are 65 %, 85 % and 95 %. Separators are installed after the humidifier at air speeds above 3,5 m/s.

## Atomizer Humidifiers

Atomizer humidifiers pump water at high pressure through stainless steel nozzles to produce a very fine and uniform fog. It doesn't require the use of a compressor or installation of a compressed air line. The system requires a water treatment device. There are models ranging from 60-500 kg/h. operating with or without inverter. The humidifier operates with demineralized water. Energy consumption is just 4 watts per kg/h humidification. The system is in compliance with the hygiene standard VDI 6022.

## Sound Attenuators

Noise level which is a significant factor in ventilation systems is reduced to an acceptable level with the aid of silencers. Insertion loss of the attenuators varies depending on the length of the splitters and frequency.

Attenuator sections consist of splitters in which rock wool is placed within the galvanized or stainless steel frame. Sound attenuator components are designed to be able to resist deformation at an air speed of up to 20 m/s. 6 different Sound Attenuator lengths are offered with the Four Season air handling units. Insertion losses for sound attenuator lengths are shown in the following charts:



### Insertion Losses for Sound Attenuators length

Splitter Length [mm]	Insertion loss [dB]							
	63 hz	125 hz	250 hz	500 hz	1000 hz	2000 hz	4000 hz	8000 hz
620	2	5	12	12	14	11	9	8
930	3	8	18	18	20	16	11	9
1240	4	11	23	24	26	19	13	11
1550	4	13	29	30	32	23	15	12
1860	5	16	34	36	38	26	16	14
2170	6	19	40	41	43	29	18	15

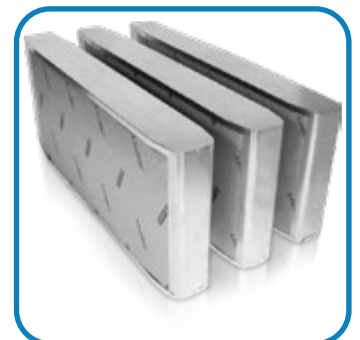



## Fans and Motors

There are various fan types and sizes in accordance with the air flow and the total static pressure. Fans are in compliance with the International standards and have been statically and dynamically balanced. Fans can be forward curved, backward curved, airfoil blade or plug, depending on the intended use and the customer's preference. Fan-motor group should be selected considering high efficiency, low noise level and minimum energy consumption, depending on the air flow and total static pressure. Fan-motor group is connected to the unit with spring isolators and flexible connections to prevent vibration.

V-belts and pulleys with taper bush are standard in our air handling units while it is possible to use adjustable pulleys on request. SPZ, SPA, SPB and SPC belt types are available. A special mechanism tensions the belt. There is a service door with lock on the fan section for service and maintenance purposes. Direct drive plug fans are used for especially in hygienic applications.

The motors with degree of protection IP55, efficiency class IE2 [EFF1] and compliant with CE norms are used as standard. They are single speed as standard and but double speed motors are available also. A frequency convertor can be provided for motor speed control.

## Inlet / Outlet Position

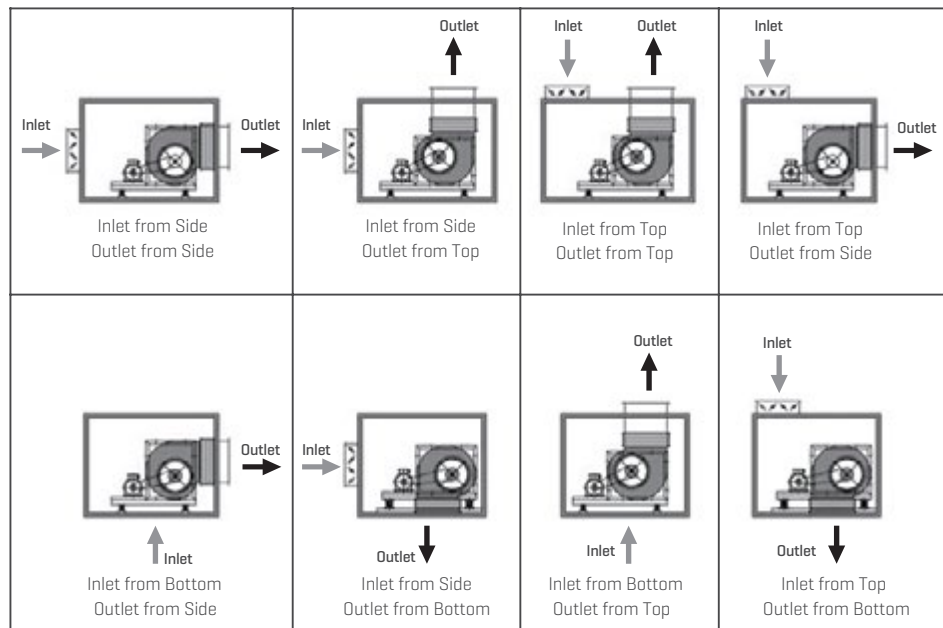

## Diffuser

Diffusers are used after the fan if there are components like filters, coils and sound attenuators after the fan, in order to allow for the equal distribution of air on these components.

## Controller and Control Functions

Function - Equipment	Definition	Standard - S Optional - OPT
Emergency stop button	Emergency stop button which stops the fan in case of an emergency	
Electric terminal box on the outer wall of the unit	Electric motor cables are wired to a terminal box on the outer wall of the unit to make on site electrical connections easy.	
<b>Automatic Control</b> Electronic control panel Duct type temperature sensor Duct type humidity sensor Valve servomotors Damper servomotors Frequency converters	Air temperature control at the point or points desired Humidity control at the point or points desired Control of two-way and three-way valves Control of dampers Control of air pressure	
<b>Microprocessor Control</b> Microprocessor Duct type temperature sensor Duct type humidity sensor Differential pressure transmitter Valve servomotors Damper servomotors Frequency converters	<ul style="list-style-type: none"> <li>- Air volume is controlled. The pressure between two locations can be controlled. In case the desired volume is not attained (blocking, failure, contamination), alarm data is generated.</li> <li>- Adjustment of desired fan volume flow rate according to the operating altitude and temperature.</li> <li>- The algorithms of pre-heating, heating and cooling can be performed according to inlet, outlet or pre-heating temperatures as desired. The limit of the outlet temperature can be controlled.</li> <li>- Contamination of all filters used can be detected and alarm data is generated.</li> <li>- Efficient operating conditions are attained by means of DX coil control.</li> <li>- It is possible to see and change all parameters via terminal located on the unit.</li> <li>- All units can be communicated as a network.</li> <li>- Operation and configuration parameters can be password-protected.</li> <li>- Audio and visual alarm data can be provided.</li> <li>- Daily, weekly start-stop timing can be performed.</li> <li>- Turkish and English language options are available.</li> <li>- All system can be connected to a computer via additional equipment; it can be managed and accessed via internet.</li> <li>- When the configuration of the unit is changed, its parameters can be easily reconfigured (addition of humidifier, changes of valve or damper control type, changes of dehumidifier or fan control type etc.)</li> <li>- Temperature control can be performed parametrically, proportionally, proportional + integral or proportional + integral + differential.</li> <li>- The compensation can be made according to outdoor temperature and adjusted parametrically.</li> <li>- The control of the fans can be maintained parametrically, thermostatically, continually, stepwise or proportionally.</li> <li>- The starting type of fan motors can be adjusted parametrically (direct, star/delta).</li> <li>- Each component can be operated and tested one by one.</li> <li>- All kinds of alarm data is kept in the memory (Differential pressure switches, thermal relay, sensor, emergency stop, etc.)</li> <li>- It can be integrated to the building automation system via all known communication languages [Modbus, BACnet, Lon-ECHELON, LAN TCP/IP, SNMP] with an additional equipment.</li> </ul>	



\* A power board can be installed together with automation board. It can be located on the unit itself or an external type can be preferred if demanded.

## Selection Procedure

The selection and design of **GMCAIR** brand air handling units and the generation of the technical report including the performance data can be easily accomplished via **GMCAIR GCS** air handling unit selection program.

Using the air handling unit selection program:

You can determine the optimum model after seeing the air velocities on the coil surface and unit cross-section for different unit models depending on the required air flow. You can lay together the components you select and form the unit you prefer. You can define the accessories for each component. When choosing the components, you can see the brand and model alternatives, if any, along with their price ratio, and you can choose the most suitable components in terms of efficiency, price, etc. You can decide the number of sections of your unit and define the maximum section length. You can see the dimensions and weights of the unit sections. You can see the technical report including the price, schematic drawing and required data of the unit you choose. The selection procedure is given below:

## Selecting Model

The model depends on the unit sizes based on the air volume. Once the insulation thickness (50 mm or 60 mm) and the air volume is determined based on the operation (heating, cooling, ventilating), model can be selected via the air handling unit selection program. The available models are listed in table 1 on page 11.

## Selecting Coils

Coils can be easily selected via the air handling unit selection program for desired capacities or temperatures. Four Season coil dimensions are standard based on the unit sizes. You can find a table about dimensions on page 12 in table 2. Coils shall be installed before fans and it is recommended that filters should be used before coils to protect coil from dusts, impurities etc. and keep it clean and provide it long life.

## Selecting Filters

The filter selection depends on the desired air quality. The optimum filter selection can be made via the air handling unit selection program based on the job needs. You can see the filter classes in table 4 [EN779:2012], table 5 and table 6 [EN1822:2010] on pages 13,14. Filters shall be installed before fans, coils, heat exchangers, humidifiers. Fine filters and high efficiency filters shall be installed after a coarse filter to provide their long life.

## Selecting Humidifiers

OEM type steam humidifiers are being used in **Gmcair** Air Handling Units and can be selected via the air handling unit selection program. Multiple humidifiers can be used based on job needs. You can find information about humectation capacities on pages 15,16 in table 7,8,9.

## Selecting Sound Attenuators

The right muffler between 6 different sized mufflers can be selected via the air handling unit selection program based on job needs. You can see The Sound Attenuators Sound Absorption Capacities Table on page 7. The sound attenuators shall be installed in return or supply units, after or before fans.

## Selecting Fans

The fan selection can be easily made via the air handling unit selection program based on the air flow and total static pressure. Total static pressure depends on job requirements and pressure drops of components being used in the air handling unit. Forward curved, backward curved and aerofoil fans are available for **Gmcair** Air Handling Units. The fan rating curves of our most used fans are on pages 17-39. You can find information about fan and motor arrangements of our most used fans on pages 40,41. in table 10,11,12,13. Fan parameters should be calculated at sea level.

# Model Information

MODELS		Unit Inner Cross-Sectional Dimensions [mm]		Airflow Range [m3/h]		
				Heating Cooling Ventilating	Cooling	Heating Ventilating
50 mm	60 mm	W	H	minimum	maximum	maximum
GCS-50062 - 046	KKS-60 062 - 046	620	465	926	1852	2469
GCS-50062 - 062	KKS-60 062 - 062	620	620	1234	2469	3292
GCS-50077 - 062	KKS-60 077 - 062	775	620	1646	3292	4389
GCS-50093 - 062	KKS-60 093 - 062	930	620	2057	4115	5486
GCS-50077 - 077	KKS-60 077 - 077	775	775	2265	4530	6039
GCS-50093 - 077	KKS-60 093 - 077	930	775	2831	5662	7549
GCS-50124 - 062	KKS-60 124 - 062	1240	620	2880	5761	7681
GCS-50093 - 093	KKS-60 093 - 093	930	930	3345	6691	8921
GCS-50124 - 077	KKS-60 124 - 077	1240	775	3963	7927	10569
GCS-50124 - 093	KKS-60 124 - 093	1240	930	4683	9367	12489
GCS-50124 - 108	KKS-60 124 - 108	1240	1085	5404	10807	14409
GCS-50155 - 093	KKS-60 155 - 093	1550	930	6022	12043	16057
GCS-50124 - 124	KKS-60 124 - 124	1240	1240	6481	12962	17282
GCS-50155 - 108	KKS-60 155 - 108	1550	1085	6947	13895	18526
GCS-50155 - 124	KKS-60 155 - 124	1550	1240	8332	16665	22220
GCS-50186 - 124	KKS-60 186 - 124	1860	1240	10184	20368	27158
GCS-50155 - 155	KKS-60 155 - 155	1550	1550	10651	21301	28402
GCS-50186 - 155	KKS-60 186 - 155	1860	1550	13018	26035	34713
GCS-50217 - 155	KKS-60 217 - 155	2170	1550	15384	30769	41025
GCS-50186 - 186	KKS-60 186 - 186	1860	1860	15281	30561	40748
GCS-50217 - 186	KKS-60 217 - 186	2170	1860	18059	36118	48157
GCS-50248 - 186	KKS-60 248 - 186	2480	1860	20837	41675	55566
GCS-50217 - 217	KKS-60 217 - 217	2170	2170	21397	42794	57059
GCS-50248 - 217	KKS-60 248 - 217	2480	2170	24689	49378	65837
GCS-50279 - 217	KKS-60 279 - 217	2790	2170	27981	55961	74615
GCS-50310 - 217	KKS-60 310 - 217	3100	2170	31272	62545	83393
GCS-50248 - 248	KKS-60 248 - 248	2480	2480	28553	57105	76140
GCS-50279 - 248	KKS-60 279 - 248	2790	2480	32360	64719	86292
GCS-50310 - 248	KKS-60 310 - 248	3100	2480	36167	72333	96444
GCS-50341 - 248	KKS-60 341 - 248	3410	2480	39974	79947	106596

Table - 1

# Coil Dimensions Data

MODEL	Coil Dimensions					
	No of Tubes In Height	Finned Length LL (mm)	Casing Length LR (mm)	Overall Length LD (mm)	Finned Height LH (mm)	Overall Height HR (mm)
062 - 046	12	450	535	610	381	431
062 - 062	16	450	535	610	508	578
077 - 062	16	595	680	765	508	578
093 - 062	16	750	835	920	508	578
077 - 077	22	600	680	765	698,5	749
093 - 077	22	750	835	920	698,5	749
124 - 062	16	1050	1135	1230	508	578
093 - 093	26	750	835	920	825,5	896
124 - 077	22	1050	1135	1230	698,5	749
124 - 093	26	1050	1135	1230	825,5	896
124 - 108	30	1050	1135	1230	952,5	1023
155 - 093	26	1350	1435	1540	825,5	896
124 - 124	36	1050	1135	1230	1143	1213
155 - 108	30	1350	1435	1540	952,5	1023
155 - 124	36	1350	1435	1540	1143	1213
186 - 124	36	1650	1735	1850	1143	1213
155 - 155	46	1350	1435	1540	1460,5	1511
186 - 155	46	1650	1735	1850	1460,5	1511
217 - 155	46	1950	2035	2160	1460,5	1511
186 - 186	54	1650	1735	1850	1714,5	1819
217 - 186	54	1950	2005	2160	1714,5	1819
248 - 186	54	2250	2335	2470	1714,5	1819
217 - 217	64	1950	2035	2160	2032	2137
248 - 217	64	2250	2335	2470	2032	2137
279 - 217	64	2550	2635	2780	2032	2137
310 - 217	64	2850	2935	3090	2032	2137
248 - 248	74	2250	2335	2470	2349,5	2391
279 - 248	74	2550	2635	2780	2349,5	2391
310 - 248	74	2850	2935	3090	2349,5	2391
341 - 248	74	3150	3235	3400	2349,5	2391

\* This table is available for 32x28 coil geometry [32: Tubes Spacing in mm, 28: Rows Spacing in mm].

# Coils Dimensions Data

Casing Depth [TR] depends on header diameter and no of rows and these two depends on desired capacities. A table about Casing Depth [TR] based on header diameter and no of rows according to 32x28 coil geometry is given below in table – 3.

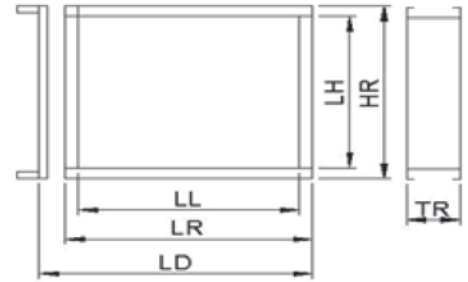

Drawing: Coil Dimensions

Casing Depth TR [Mm]								
HEADER DIAMETER	Casing Depth TR [Mm]							
	1	2	3	4	5	6	7	8
1"	110	110	145	180	215	250	285	320
1 1/4"	145	145	145	180	215	250	285	320
1 1/2"	145	145	145	180	215	250	285	320
2"	180	180	180	215	250	285	285	320
2 1/2"	215	215	215	215	250	285	285	320
3"	215	215	215	215	250	285	285	320
4"	285	285	285	285	285	320	320	320

Table – 3

# Filter Classes Data

## International Classification Of Air Filters

### EN 779:2012 Classification

Filter Group	Class	Final Pressure Drop [Pa]	Average arrestance [Am] of synthetic dust %	Average efficiency [Em] of 0,4 µm particles %	Minimum Efficiency for 0.4 µm particles %
Coarse	G1	250	50 < Am < 65	-	-
	G2	250	65 < Am < 80	-	-
	G3	250	80 < Am < 90	-	-
	G4	250	90 < Am	-	-
Medium	M5	450	-	40 < Em < 60	-
	M6	450	-	60 < Em < 80	-
Fine	F7	450	-	80 < Em < 90	35
	F8	450	-	90 < Em < 95	55
	F9	450	-	95 < Em	70

Table – 4

# Filter Classes Data

## Initial Efficiency vs. Particle Size According to EN 779:2012

Filter Group	Class	0,1 µm	0,3 µm	0,5 µm	1,0 µm	3 µm	5 µm	10 µm
Coarse	G1					0-5	5-15	40-50
	G2				0-5	5-15	15-35	50-70
	G3			0-5	5-15	15-35	35-70	70-85
	G4		0-5	5-15	15-35	30-55	60-90	85-98
Medium	M5	0-10	5-15	15-30	30-50	70-90	90-99	>98
	M6	5-15	10-25	20-40	50-65	85-95	95-99	>99
Fine	F7	25-35	45-60	60-75	85-95	>98	>99	>99
	F8	35-45	65-75	80-90	95-98	>99	>99	>99
	F9	45-60	75-85	90-95	>99	>99	>99	>99

Table - 5

## EN 1822:2010 Classification

Filter Class	Integral Value		Local Value	
	Collection Efficiency %	Penetration %	Collection Efficiency %	Penetration %
E10	85	15	-	-
E11	95	5	-	-
E12	99,5	0,5	-	-
H13	99,95	0,05	99,75	0,25
H14	99,995	0,005	99,975	0,025
U15	99,9995	0,0005	99,9975	0,0025
U16	99,99995	0,00005	99,99975	0,00025
U17	99,999995	0,000005	99,99999	0,00001

Table - 6

# Humidifiers Data

## Single Type

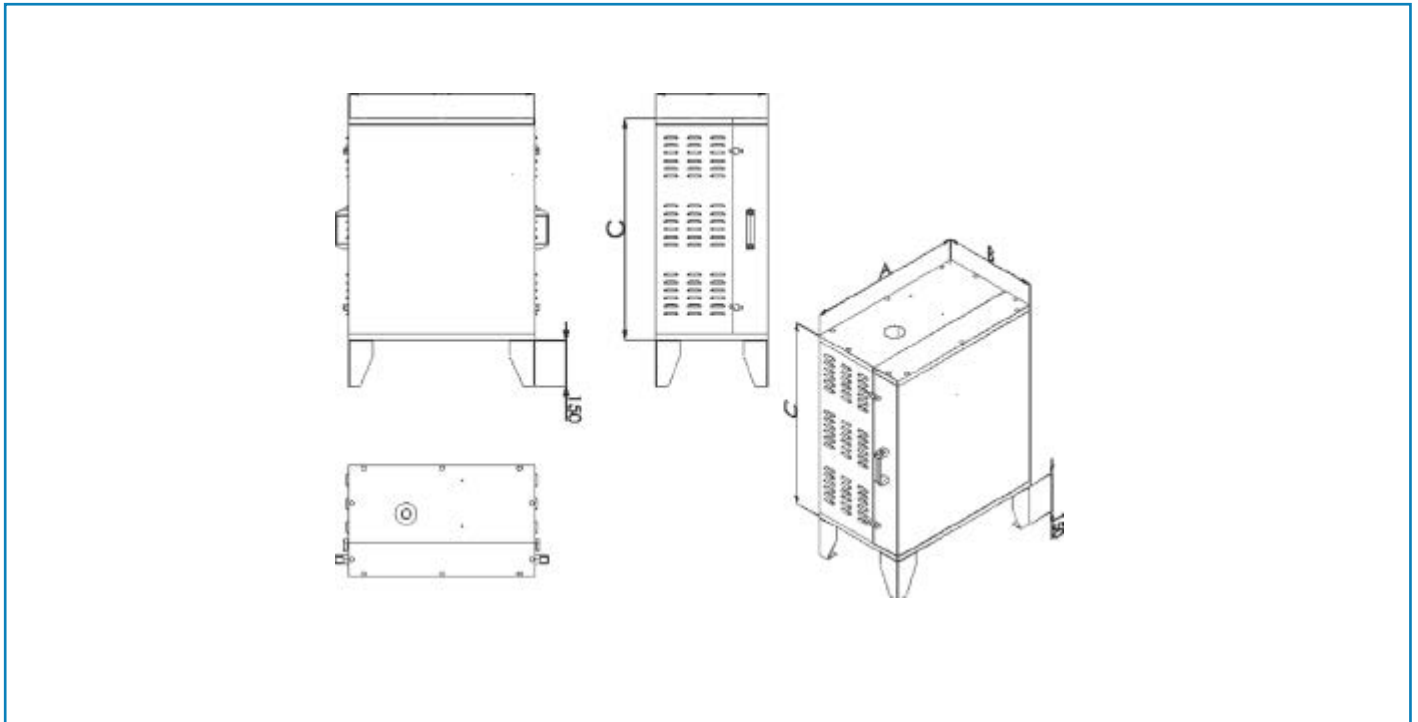

MODEL	Maximum Capacity [kg/h]	Power Consumption [kW]	Weight [kg]	Dimensions [mm]		
				A	B	C
HUM-015	15	12	32	600	360	710
HUM-045	45	36	42	650	440	810

Table - 7

## Multiple Type

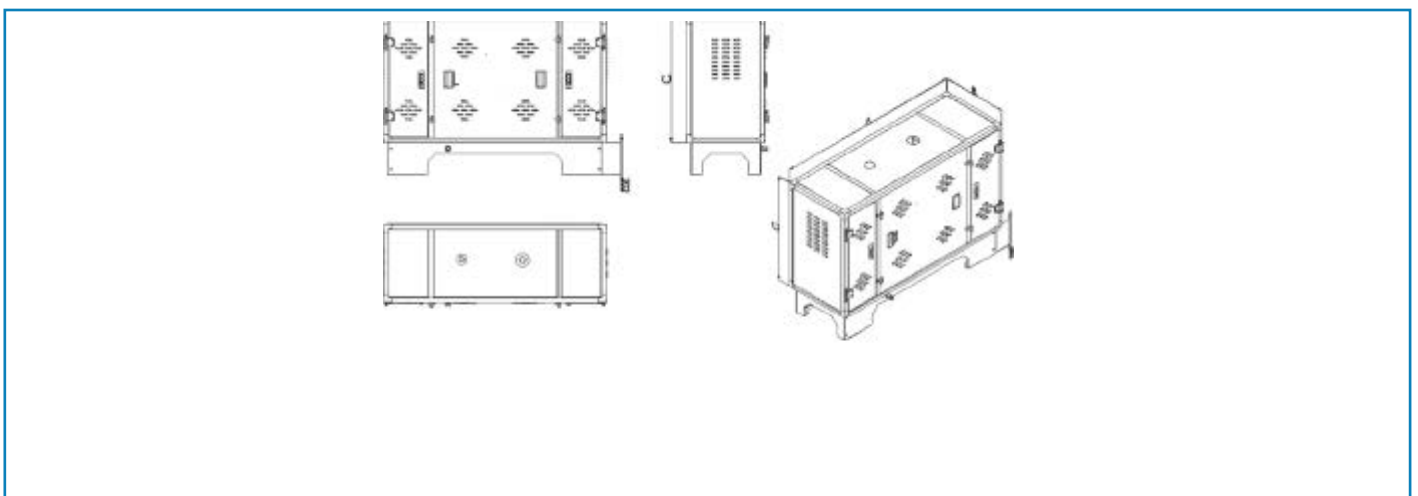

MODEL	Maximum Capacity [kg/h]	Power Consumption [kW]	Weight [kg]	Dimensions [mm]		
				A	B	C
HUM-060	60	48	90	1426	500	810
HUM-090	90	72	100	1426	500	810

Table - 8

# Humidifiers Data

## Multiple Type

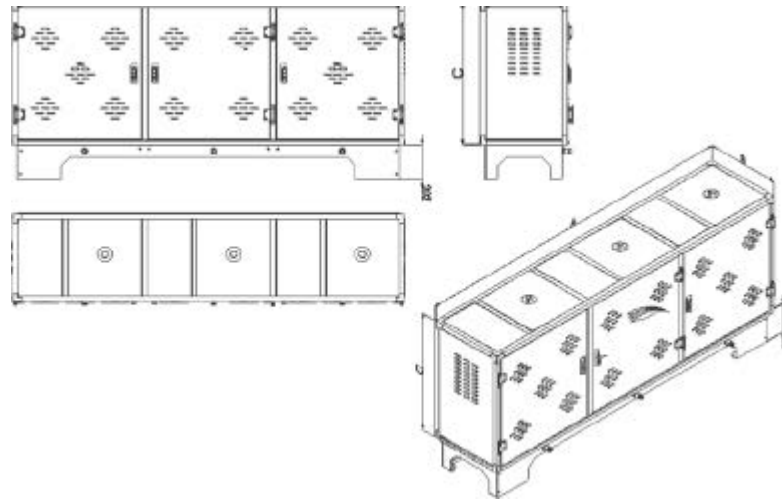

MODEL	Maximum Capacity [kg/h]	Power Consumption [kW]	Weight [kg]	Dimensions [mm]		
				A	B	C
HUM-105	105	84	135	2235	500	810
HUM-135	135	108	145	2235	500	810

Table - 9



# Fan Rating Curves

## Backward Curved Fan Data

### RDH 0280

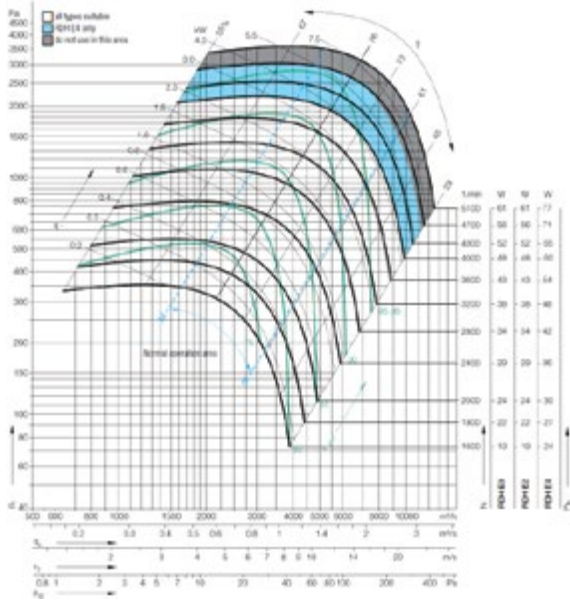

### RDH 0315

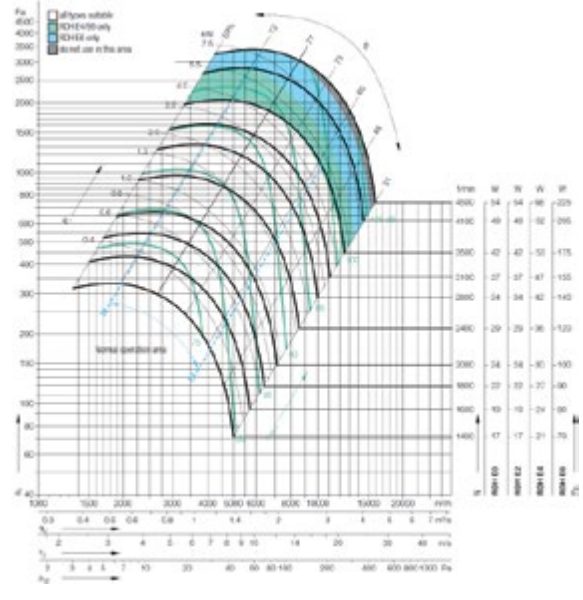

### RDH 0355

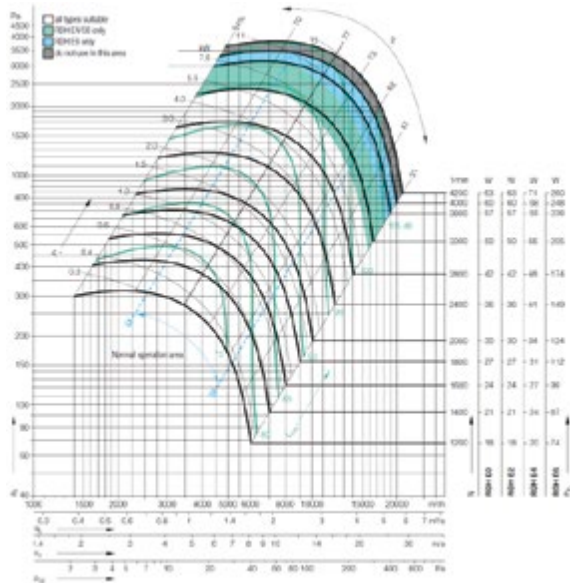

### RDH 0400

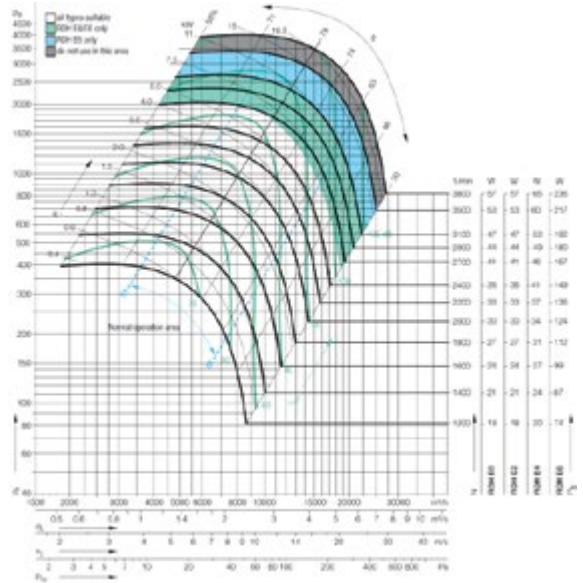

# Fan Rating Curves

## Backward Curved Fan Data

### RDH 0450

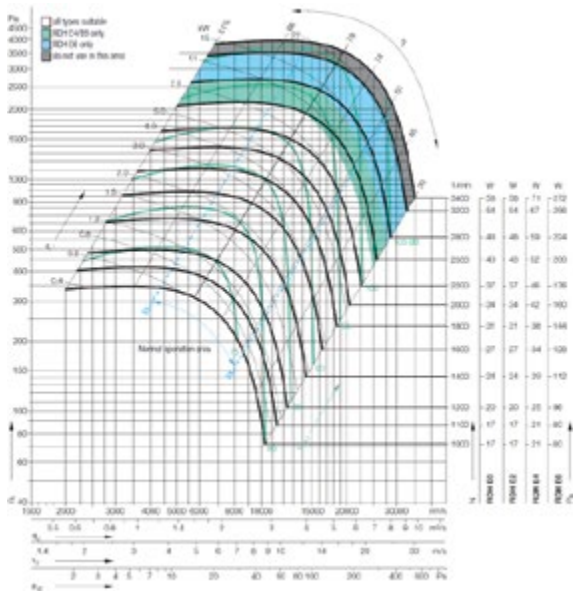

### RDH 0500

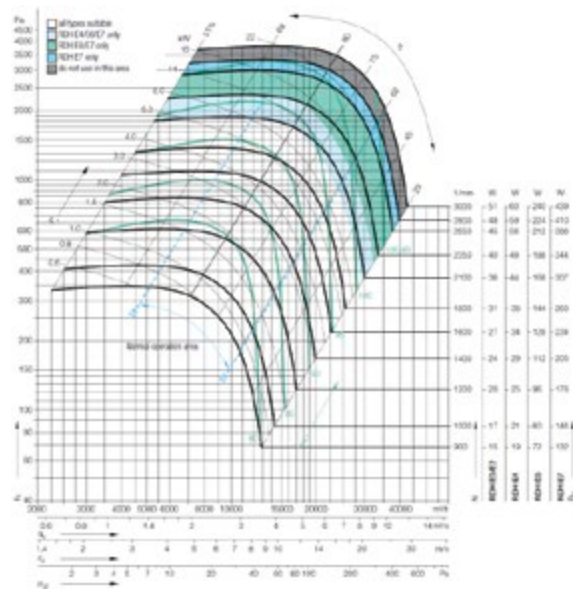

### RDH 0560

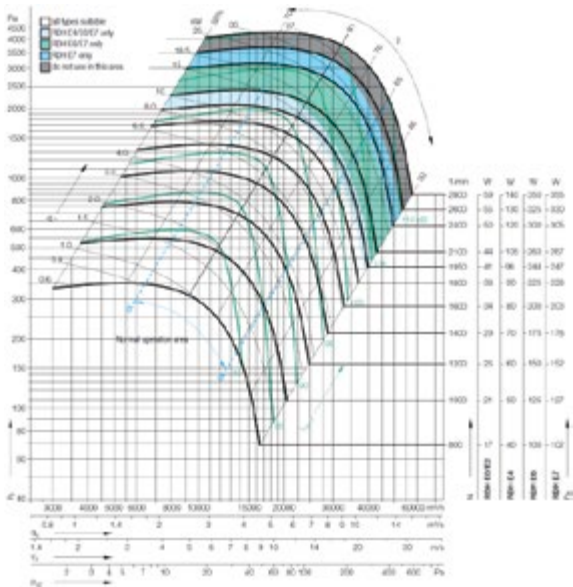

### RDH 0630

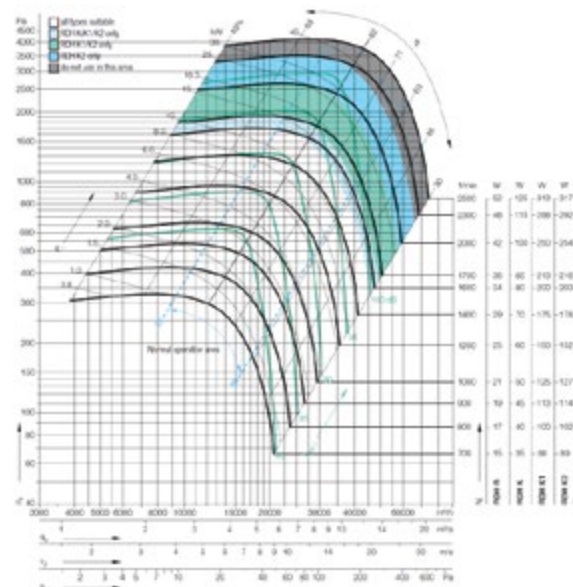

# Fan Rating Curves

## Backward Curved Fan Data

### RDH 0710

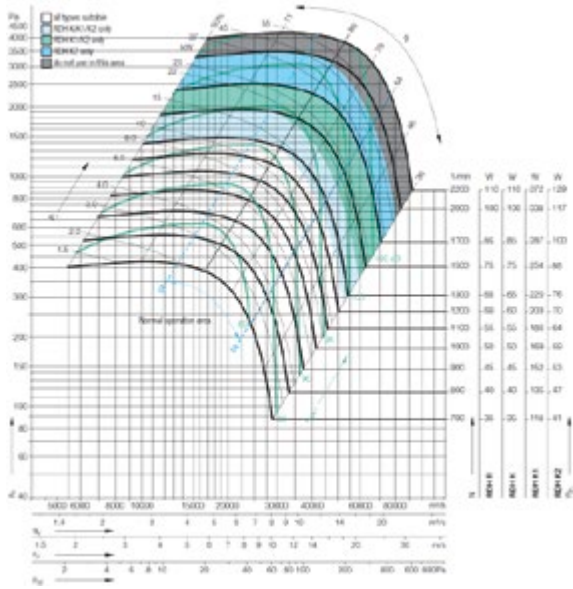

### RDH 0800

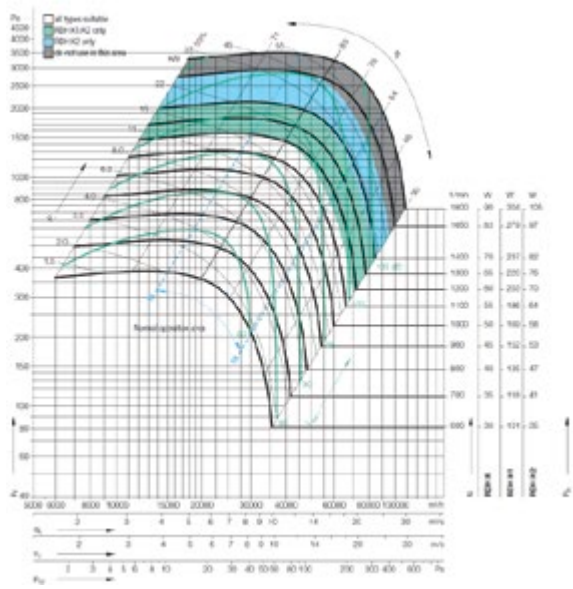

### RDH 0900

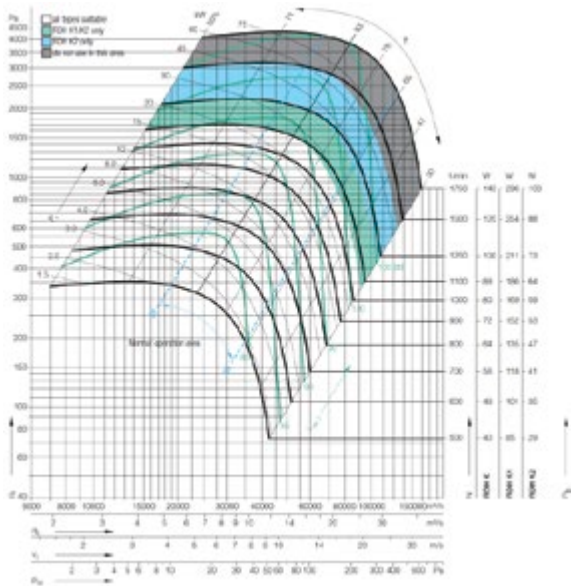

### RDH 1000

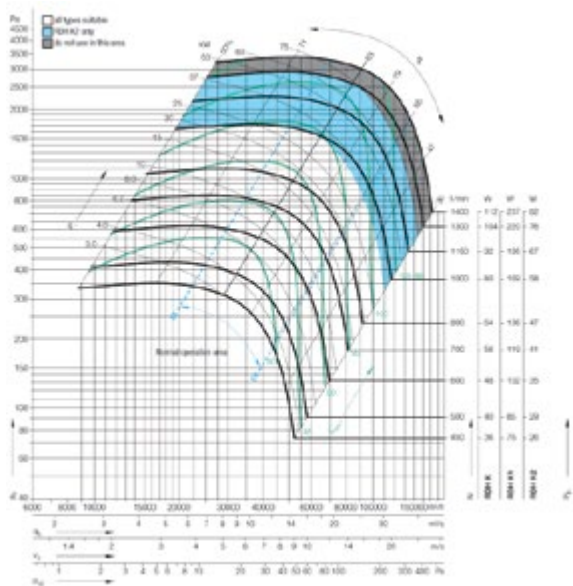

# Fan Rating Curves

## Forward Curved Fan Data

ADH 0160

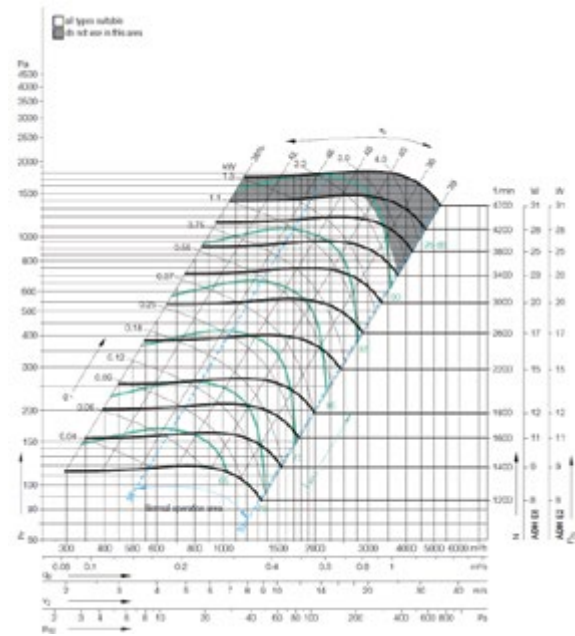

ADH 0180

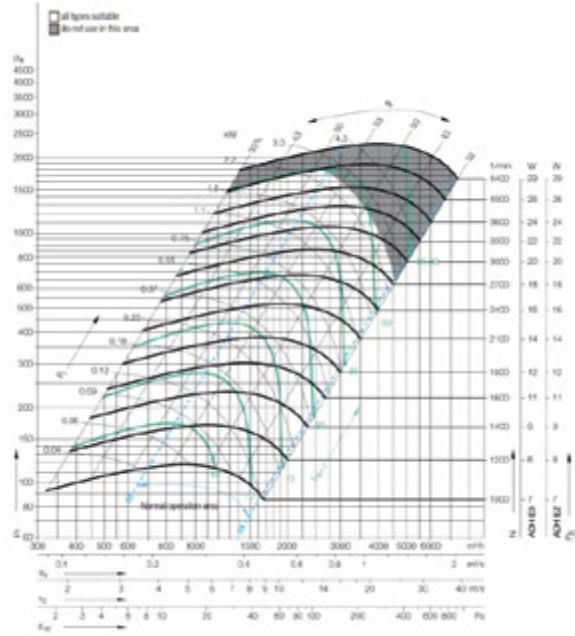

ADH 0200

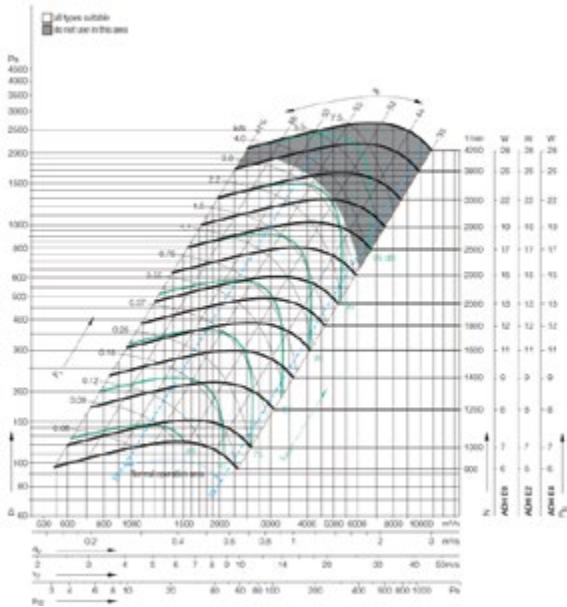

ADH 0225

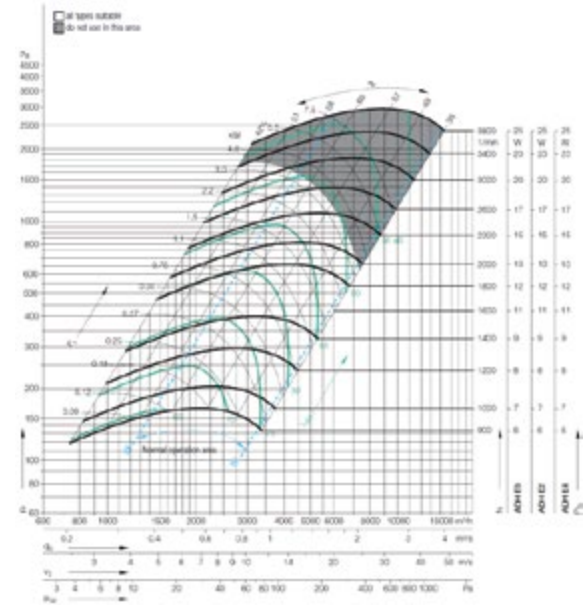

# Fan Rating Curves

## Forward Curved Fan Data

ADH 0250

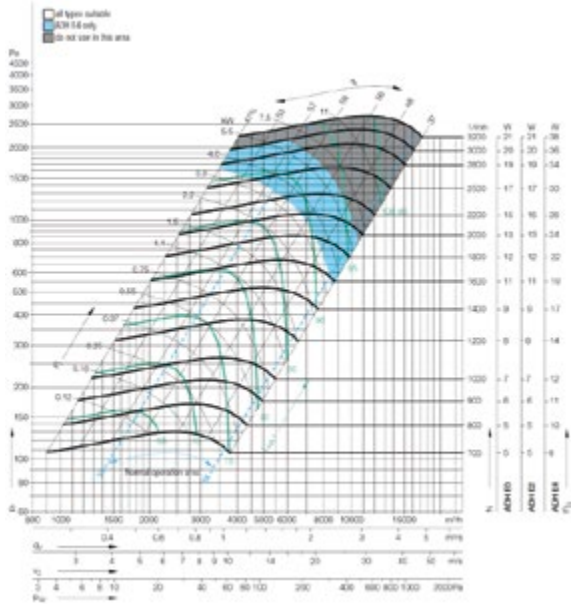

ADH 0280

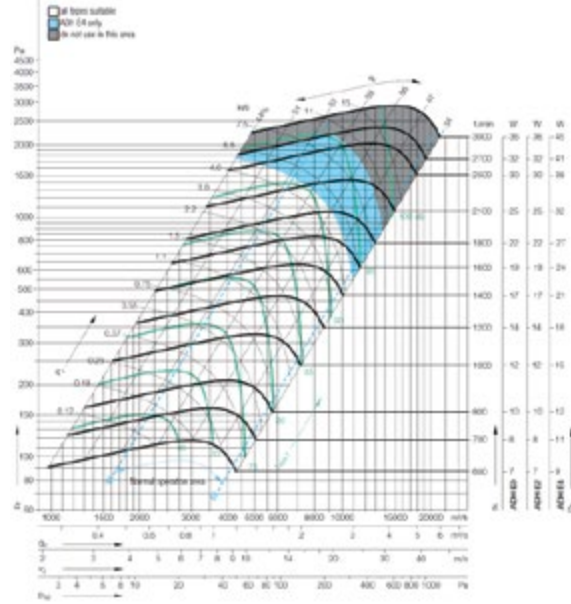

ADH 0315

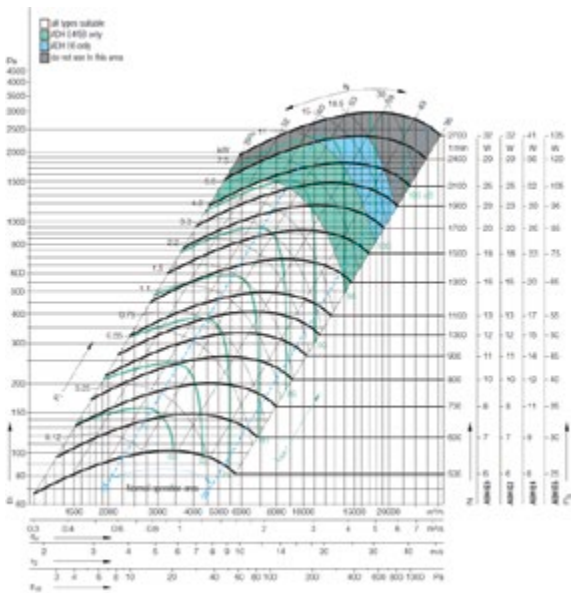

ADH 0355

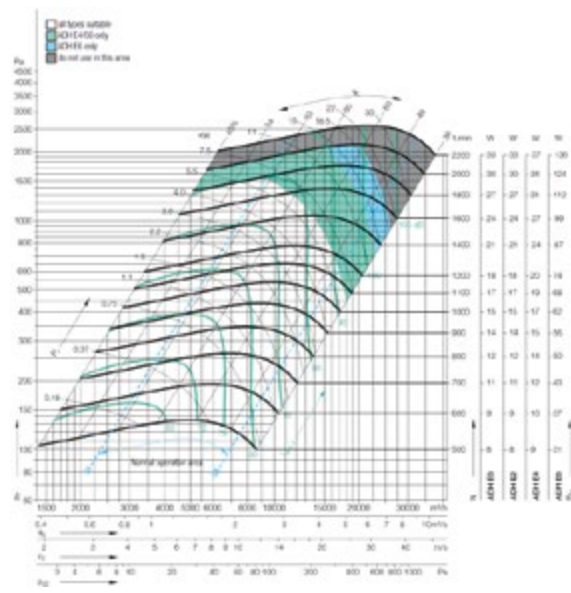

# Fan Rating Curves

## Forward Curved Fan Data

### ADH 0400

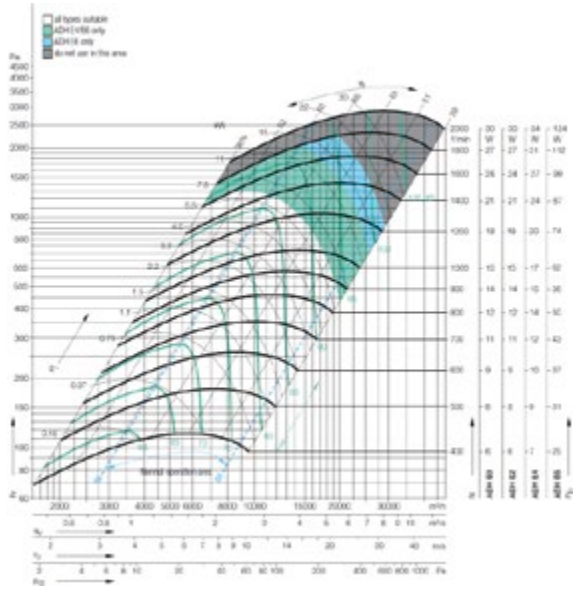

### ADH 0450

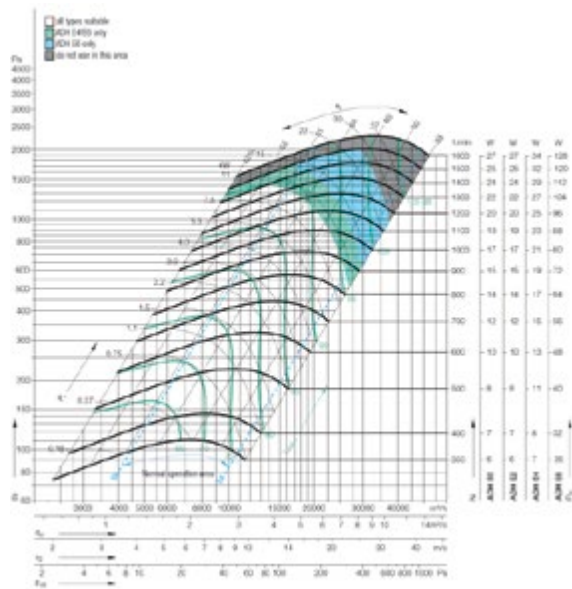

### ADH 0500

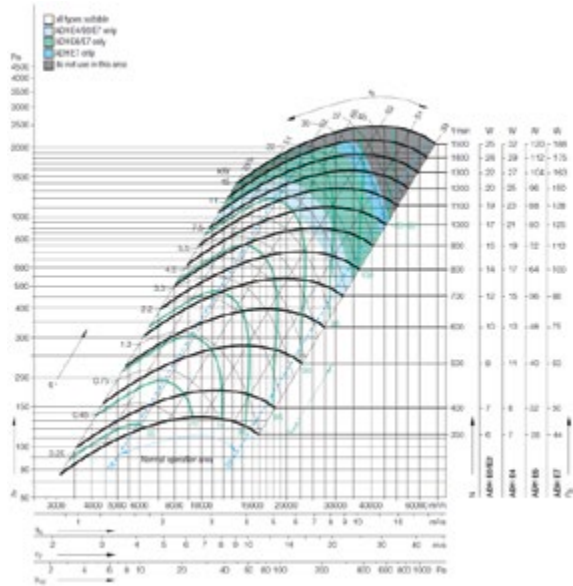

### ADH 0560

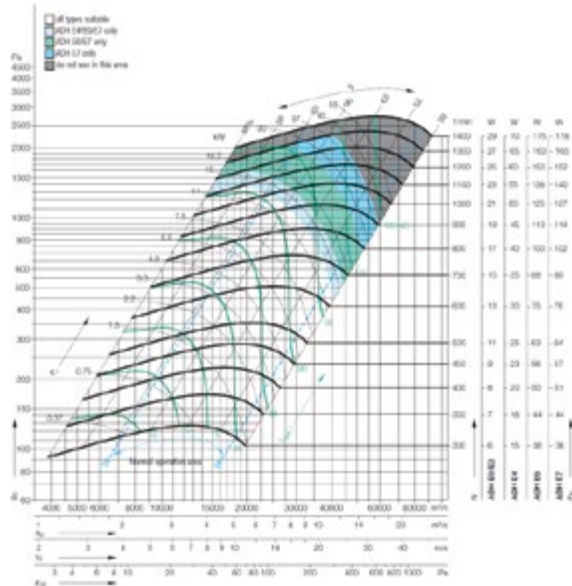

# Fan Rating Curves

## Forward Curved Fan Data

ADH 0630

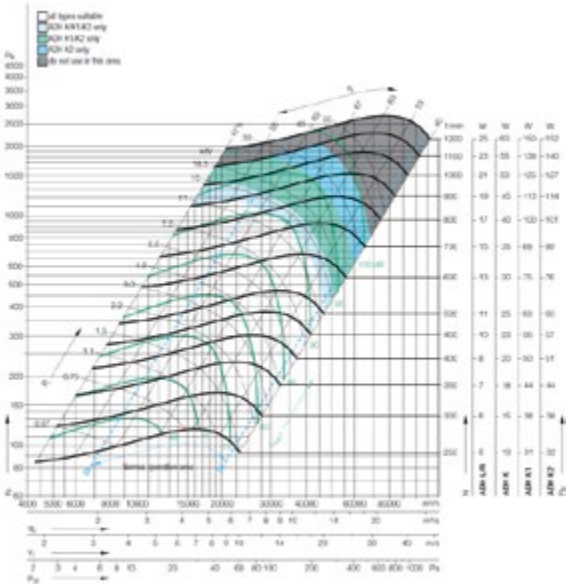

ADH 0710

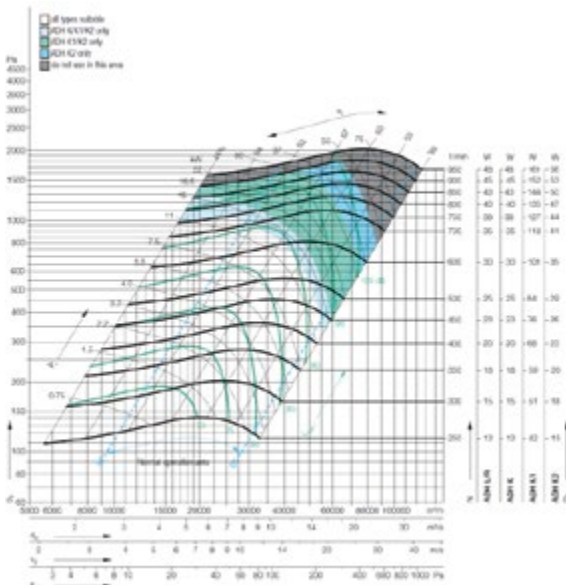

ADH 0800

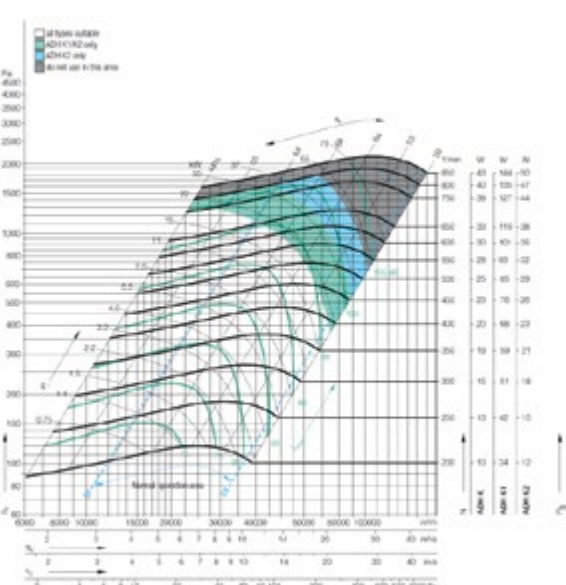

ADH 0900

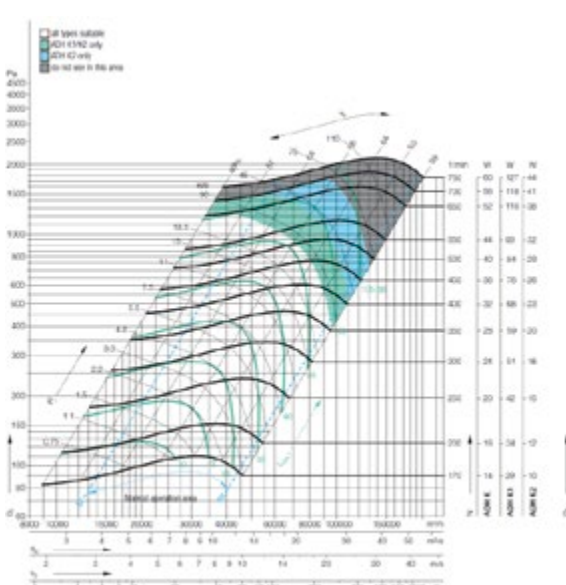

# Fan Rating Curves

## Forward Curved Fan Data

### ADH 1000

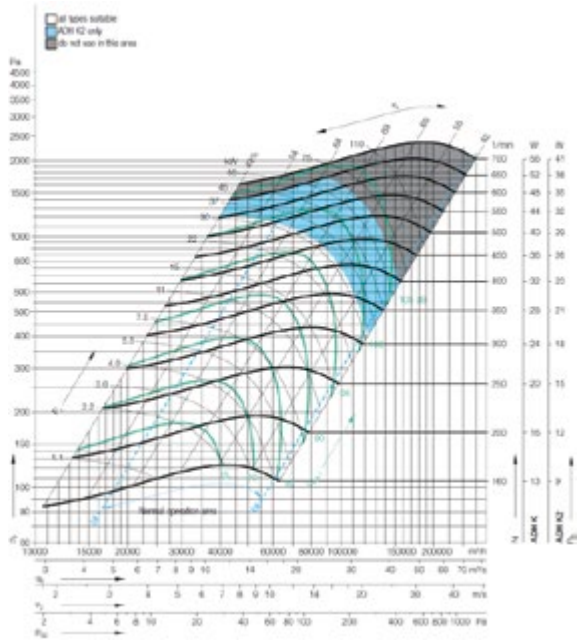

# Fan Rating Curves

## Forward Curved Fan Data

AT 7/7

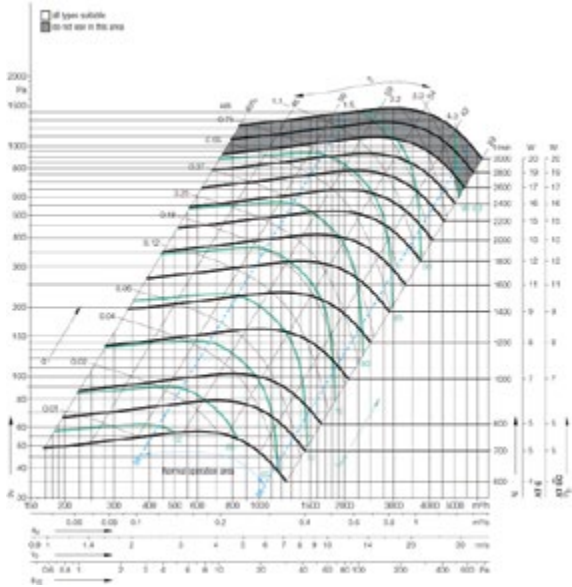

AT 9/7

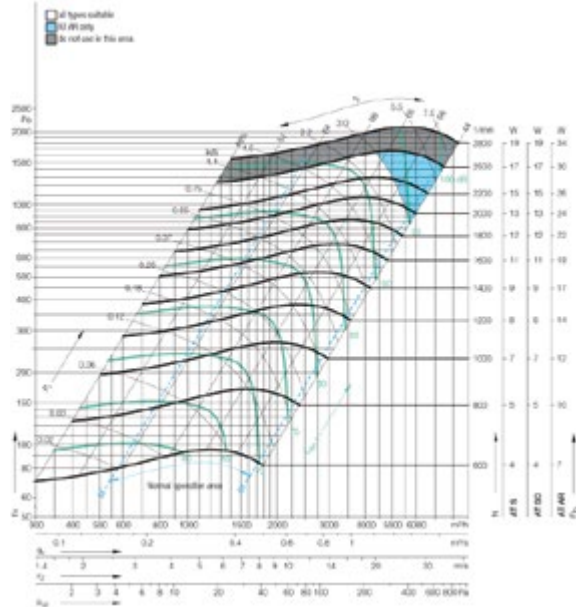

AT 9/9

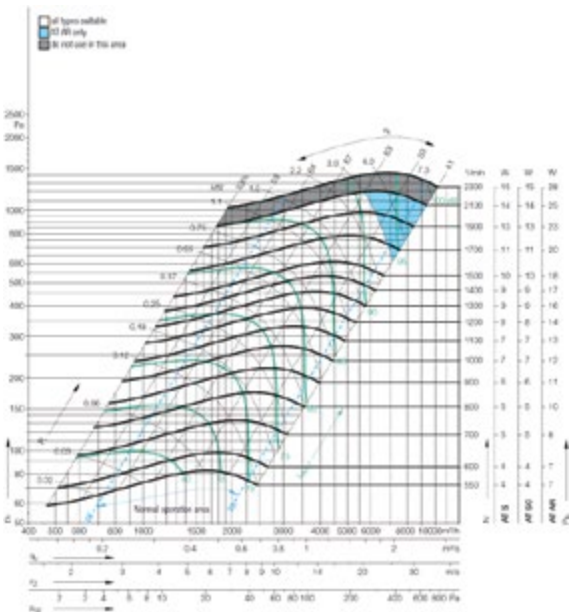

AT 10/8

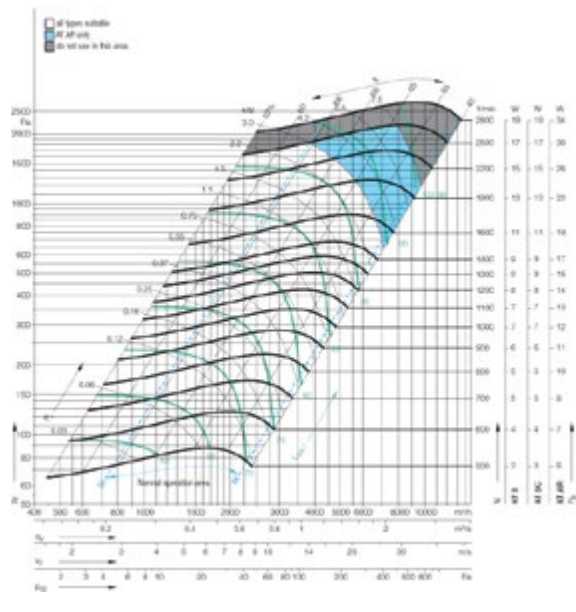

# Fan Rating Curves

## Forward Curved Fan Data

AT 10/10

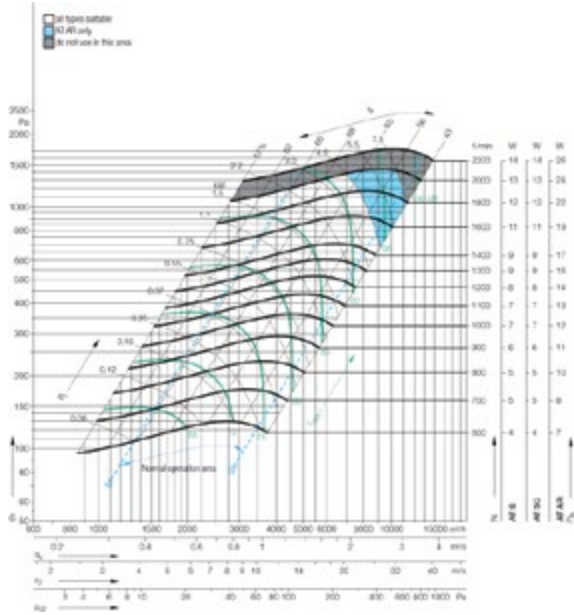

AT 12/9

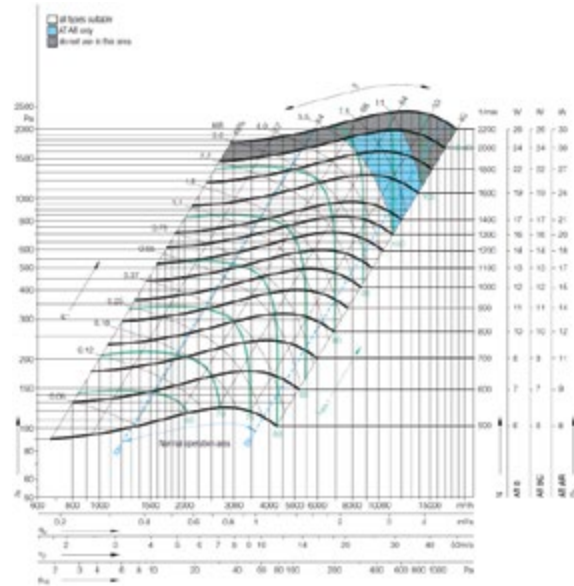

AT 12/12

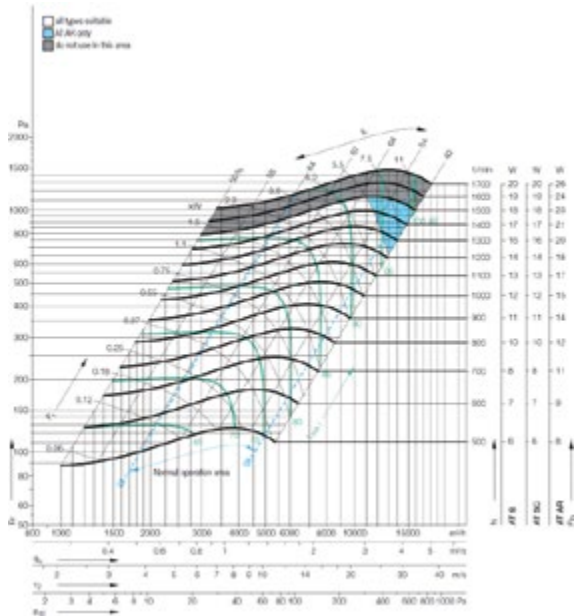

AT 15/11

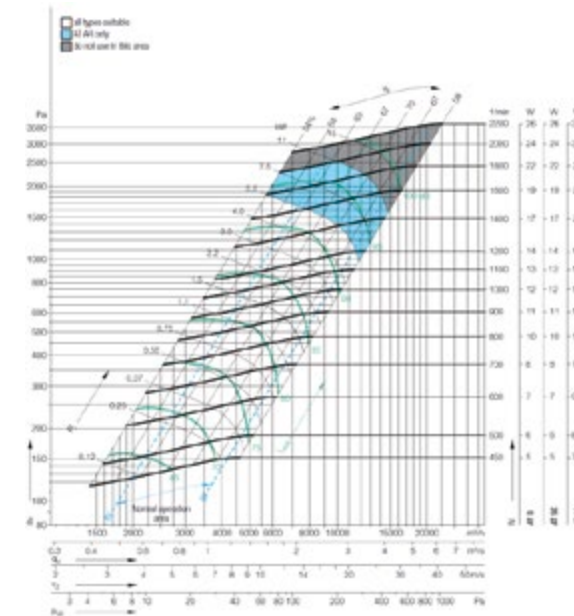

# Fan Rating Curves

## Forward Curved Fan Data

AT 15/15

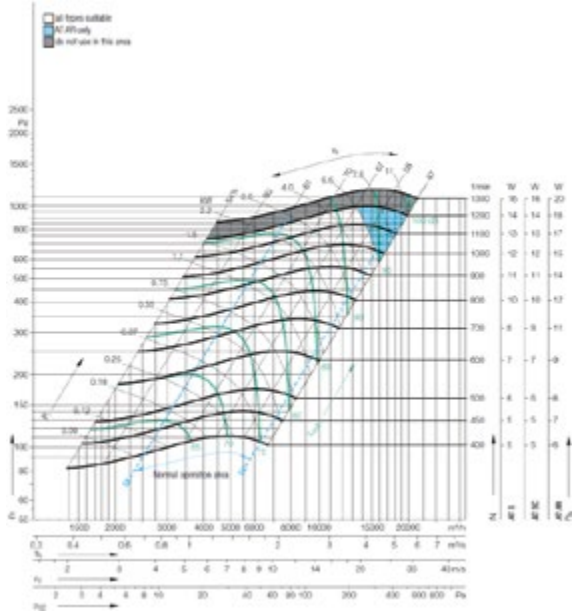

AT 18/13

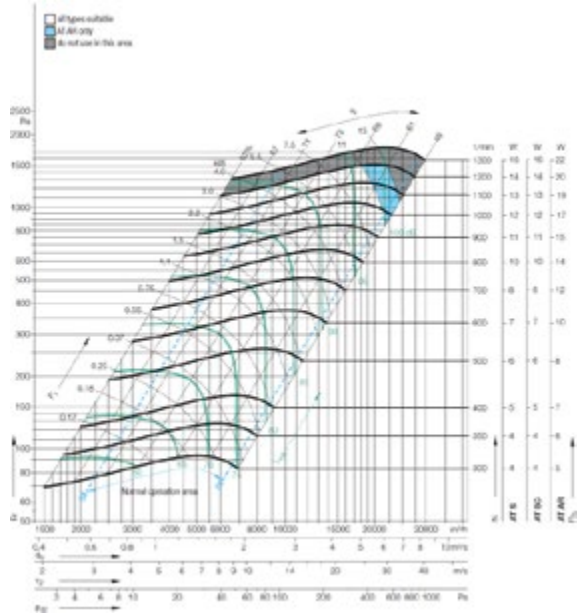

AT 18/18

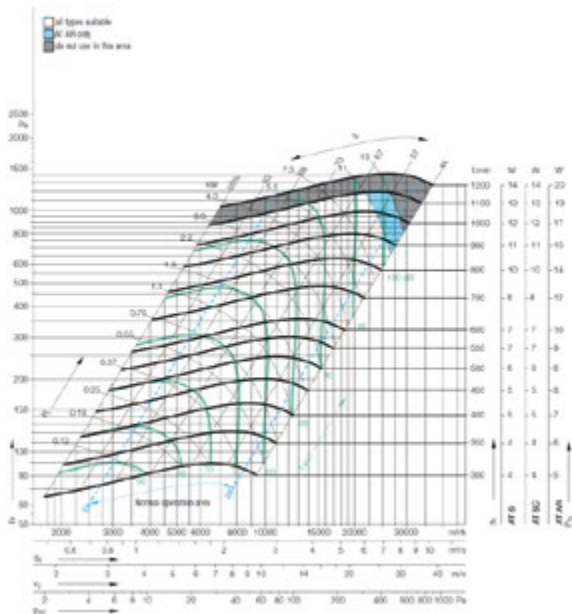

# Fan Rating Curves

## Plug Fan Data

### RLM 56-2528

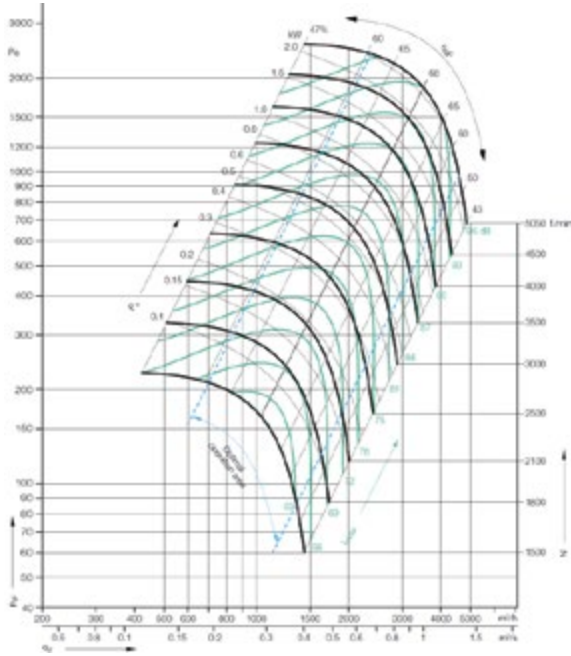

### RLM 56-2831

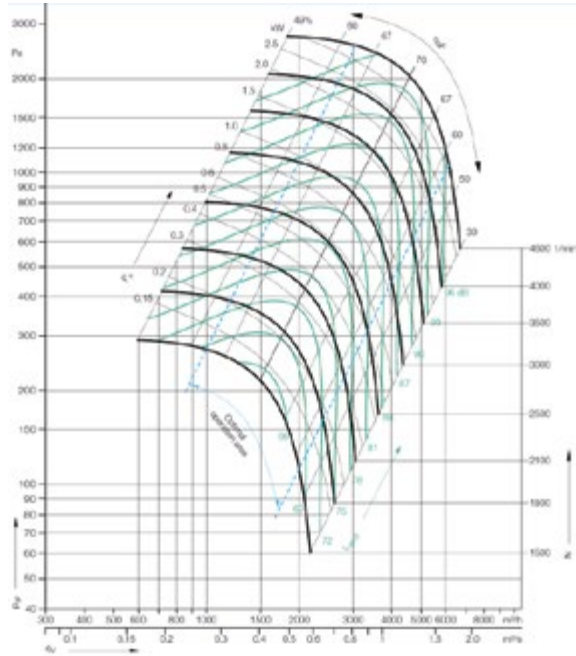

### RLM 56-3135

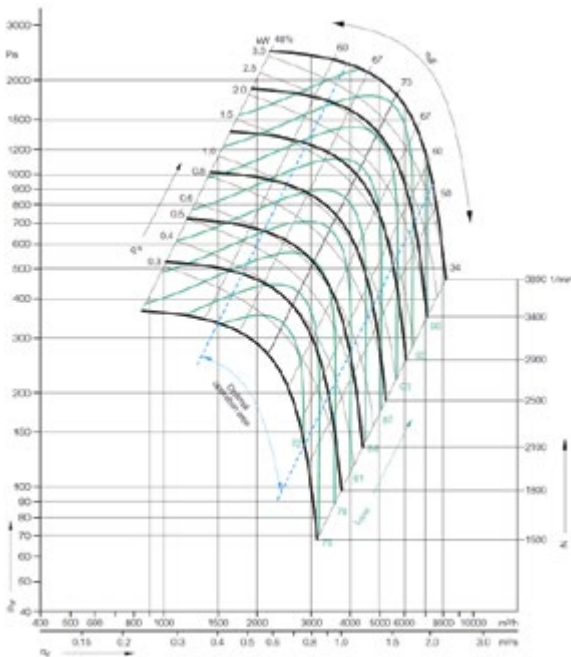

### RLM 56-3540

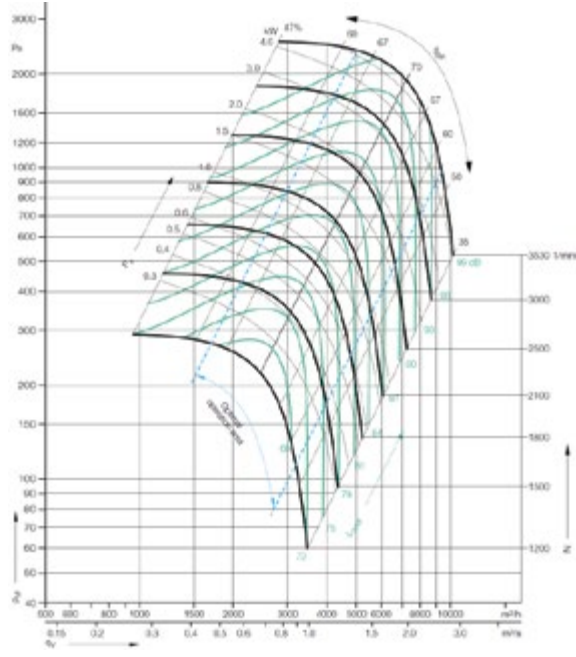



# Fan Rating Curves

## Plug Fan Data

### RLM 56-6371

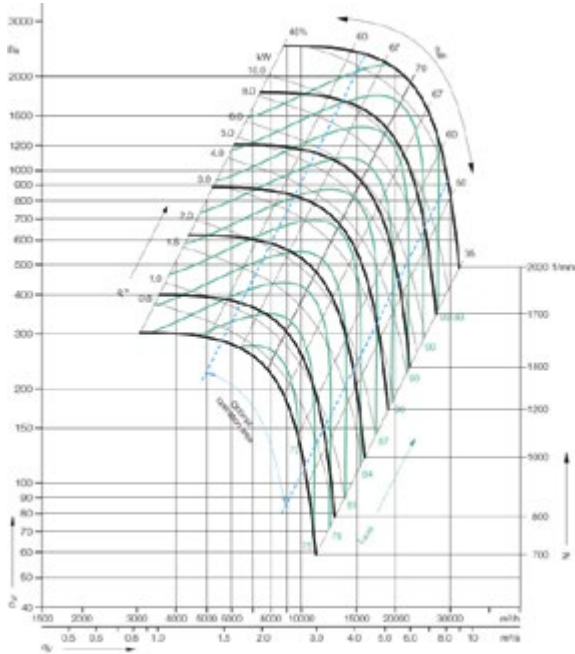

### RLM 56-7180

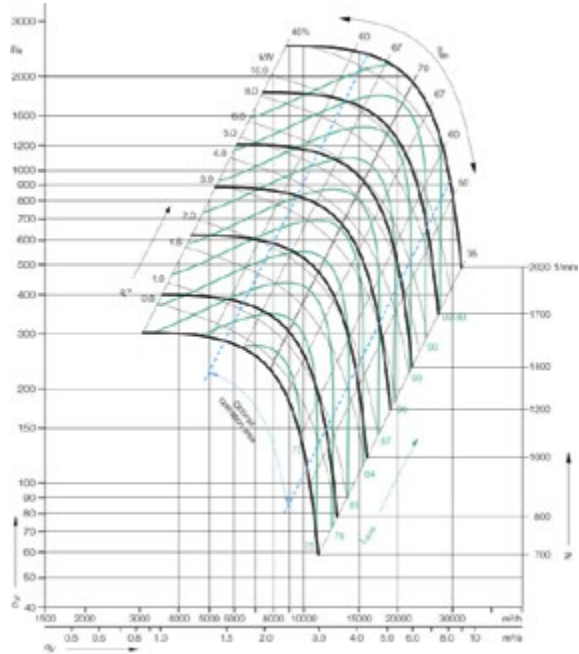

### RLM 56-8090

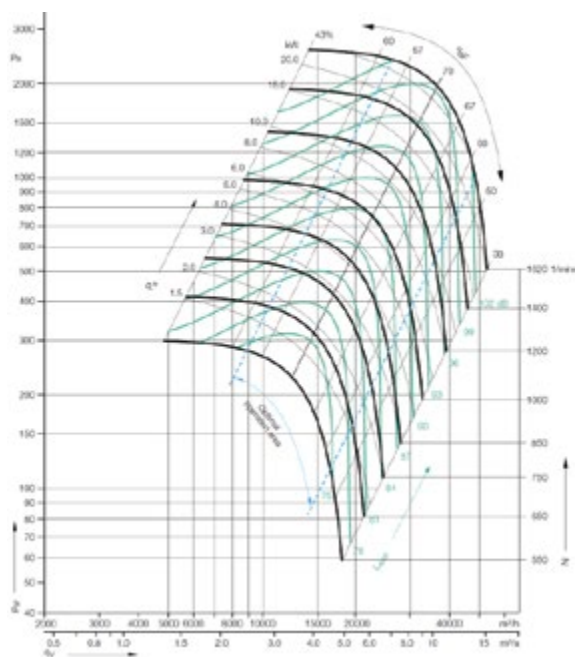

### RLM 56-9010

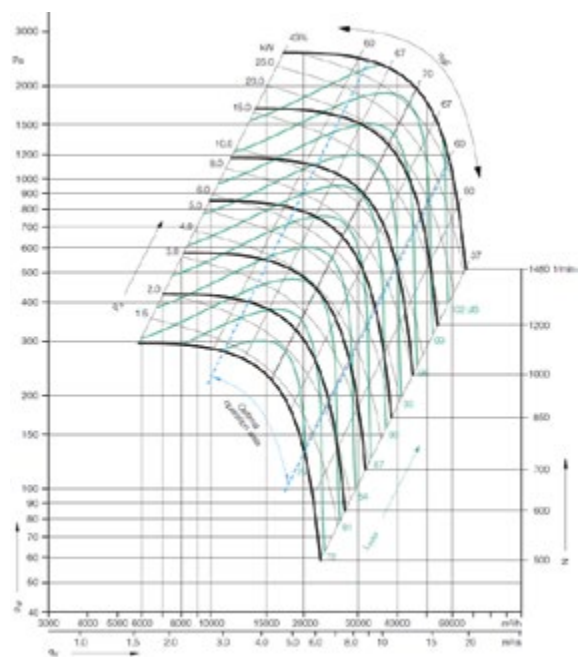

# Fan Rating Curves

## Plug Fan Data

### RLM 56-1011

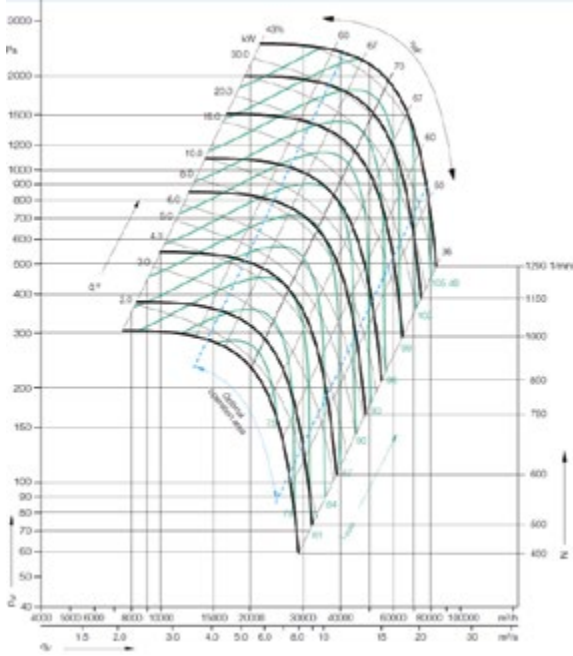

### RLM 56-1112

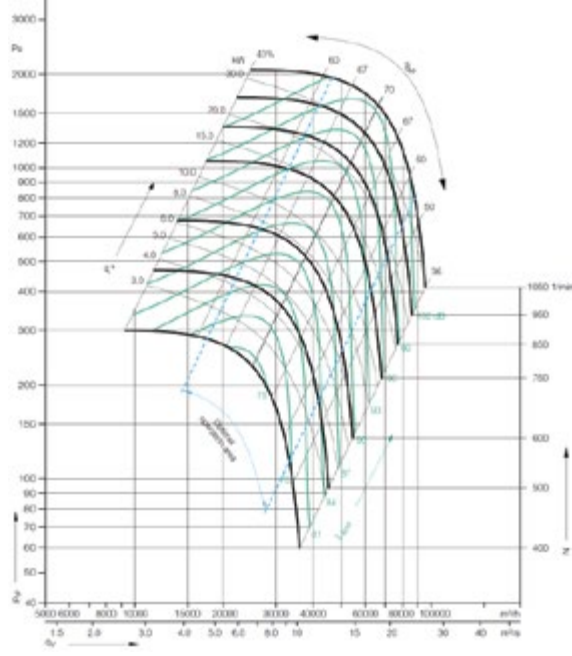

### RLM 56-1214

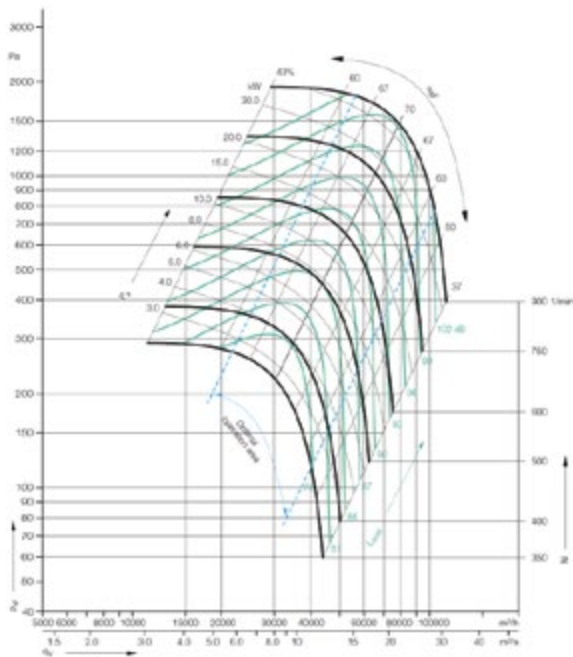

# Fan Rating Curves

## Plug Fan Data

### RLM E6-2528

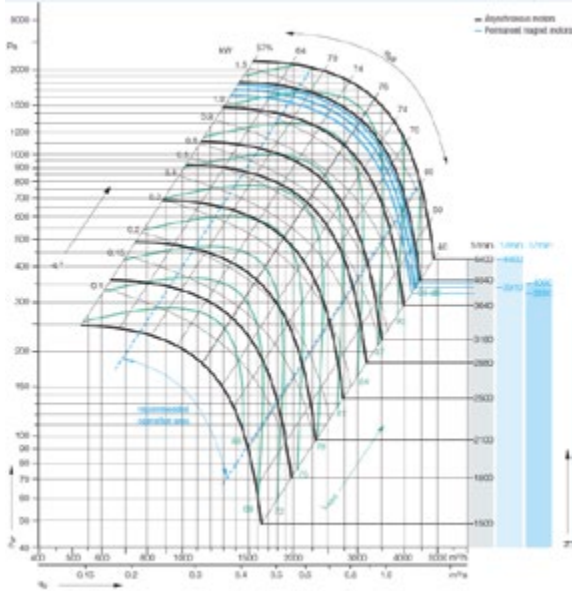

### RLM E6-2831

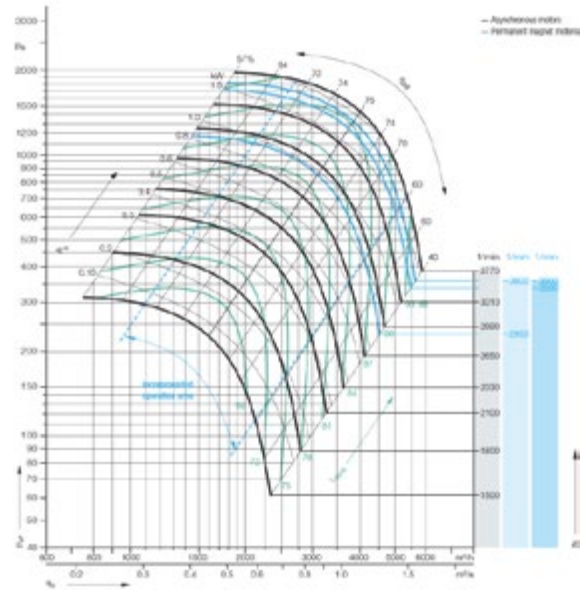

### RLM E6-3135

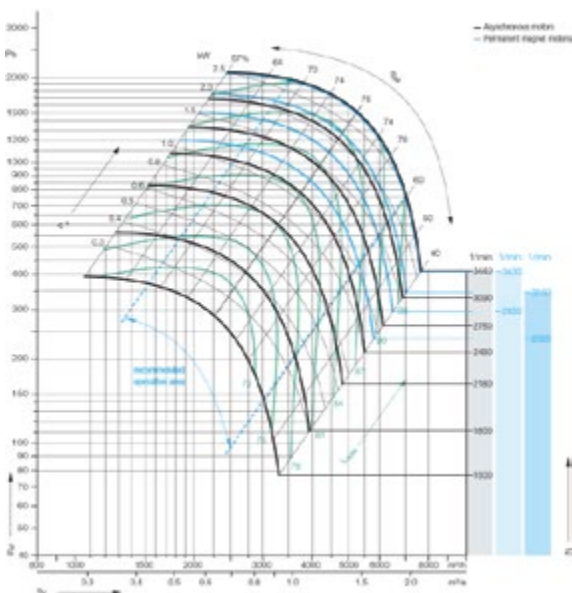

### RLM E6-3540

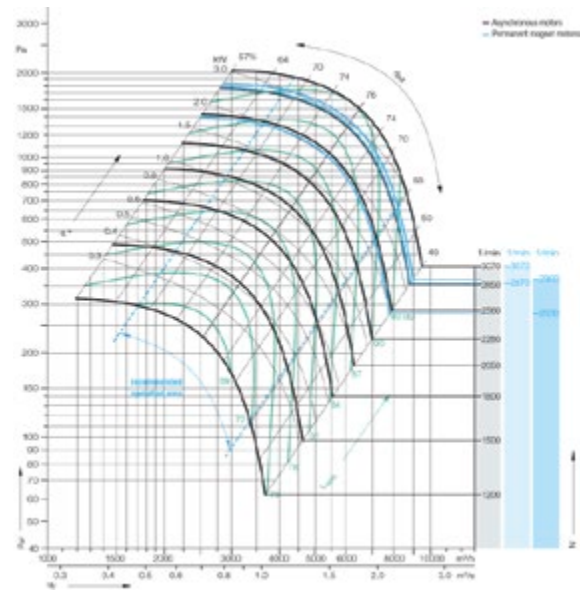

# Fan Rating Curves

## Plug Fan Data

RLM E6-4045

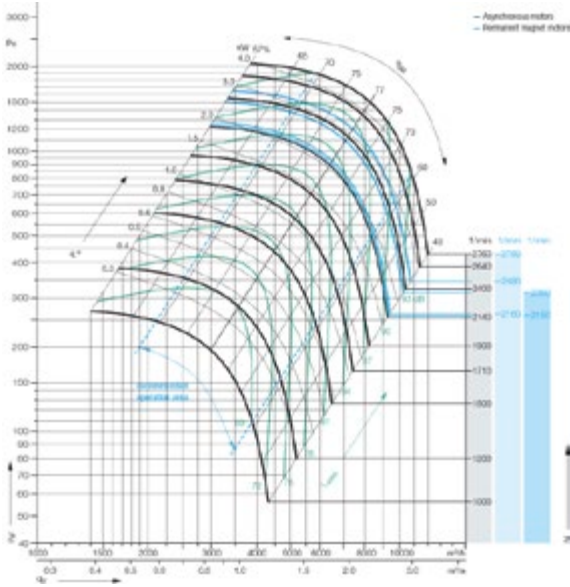

RLM E6-4550

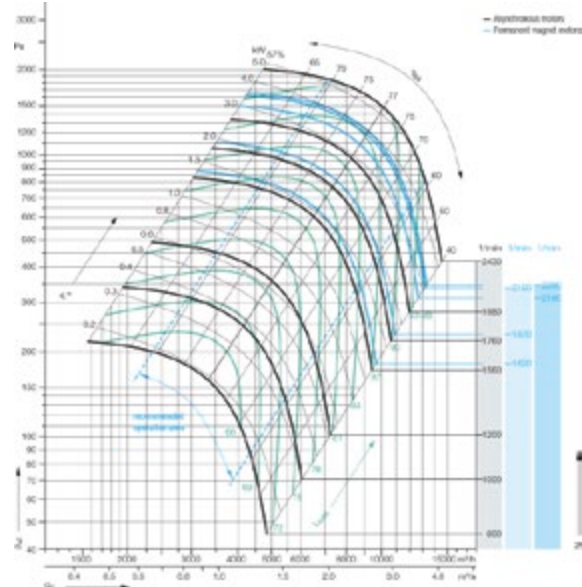

RLM E6-5056

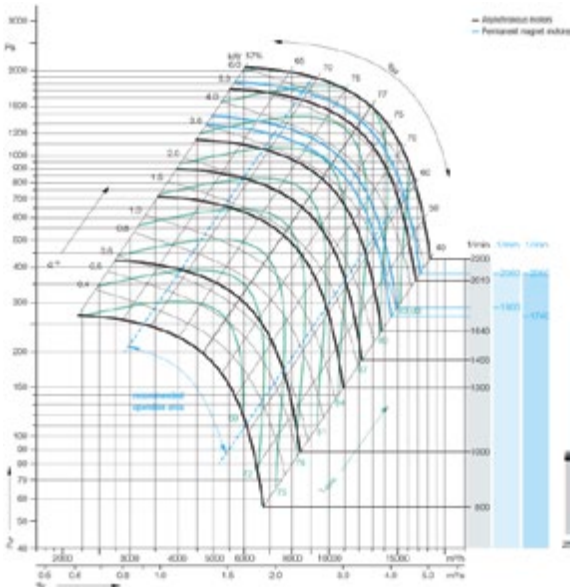

RLM E6-5663

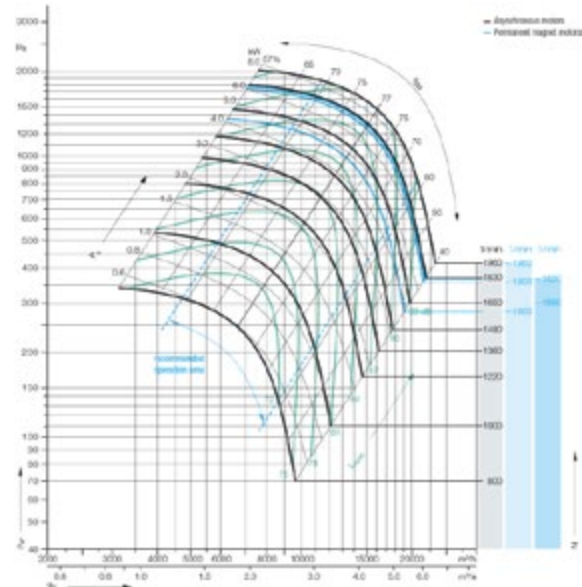

# Fan Rating Curves

## Plug Fan Data

### RLM E6-6371

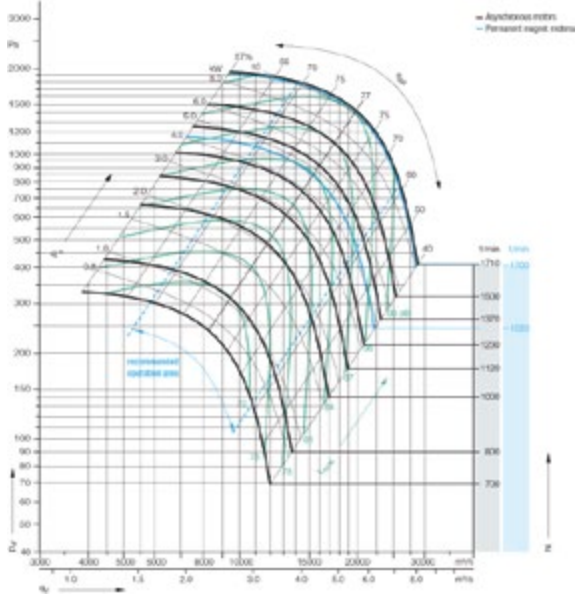

### RLM E6-7180

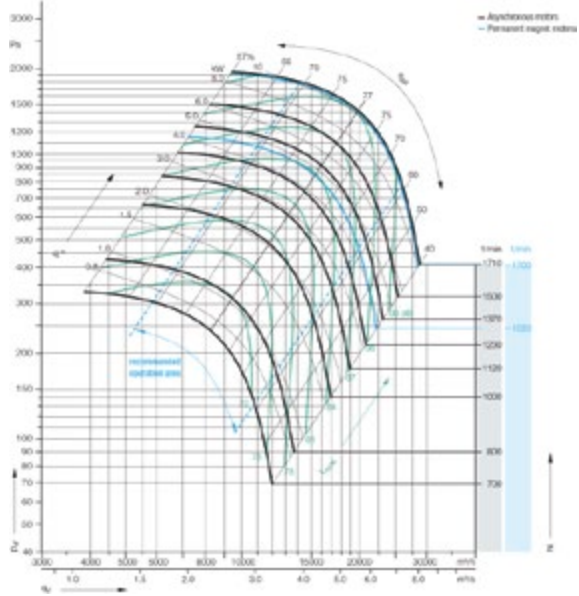

### RLM E6-8090

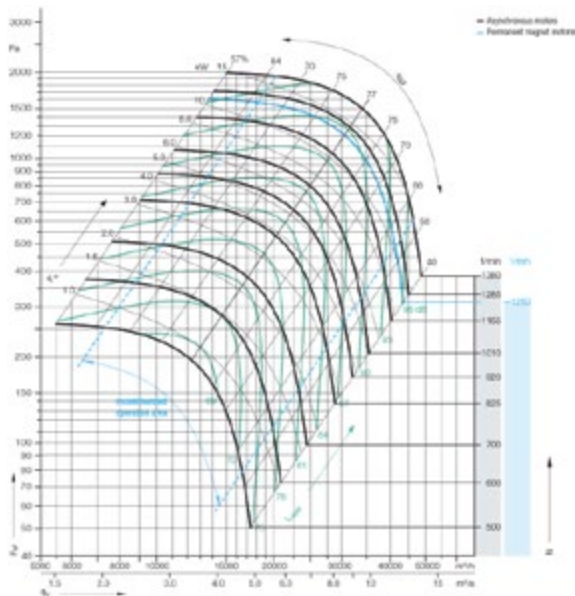

### RLM E6-9010

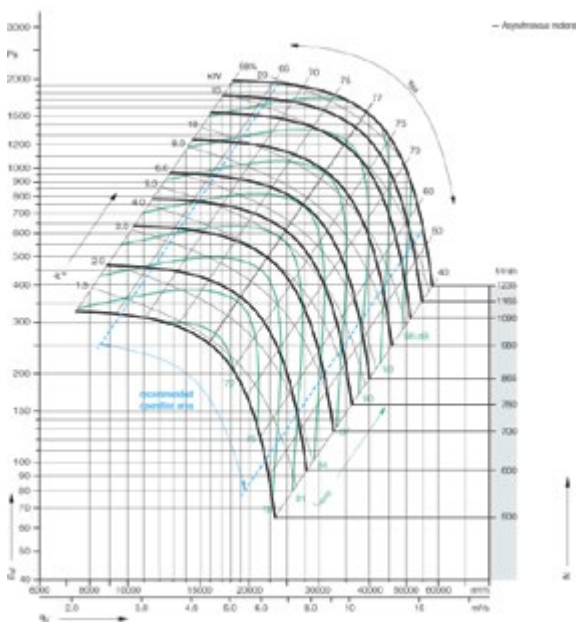



# Fan Rating Curves

## Aerofoil Fan Data

### RZR 0315

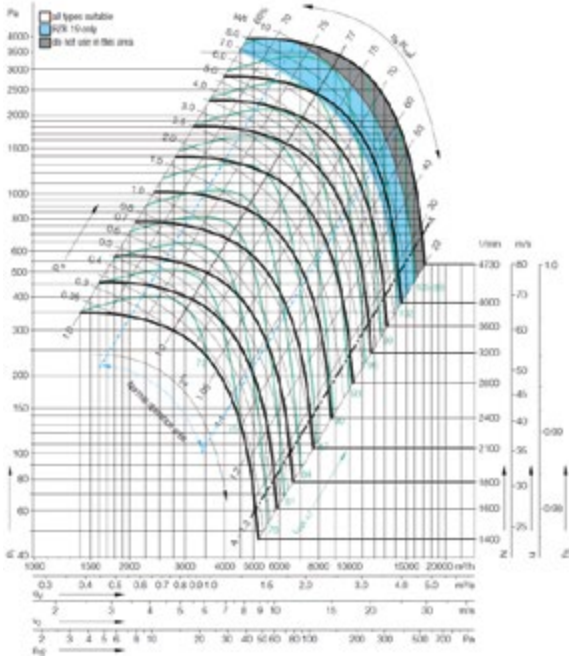

### RZR 0355

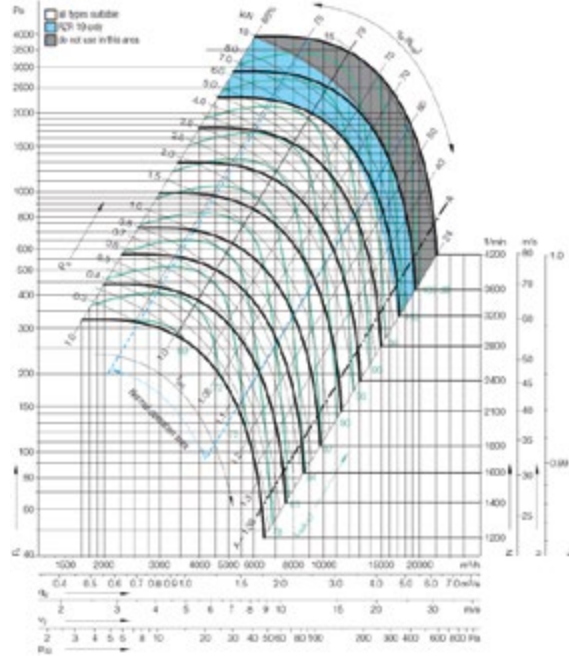

### RZR 0400

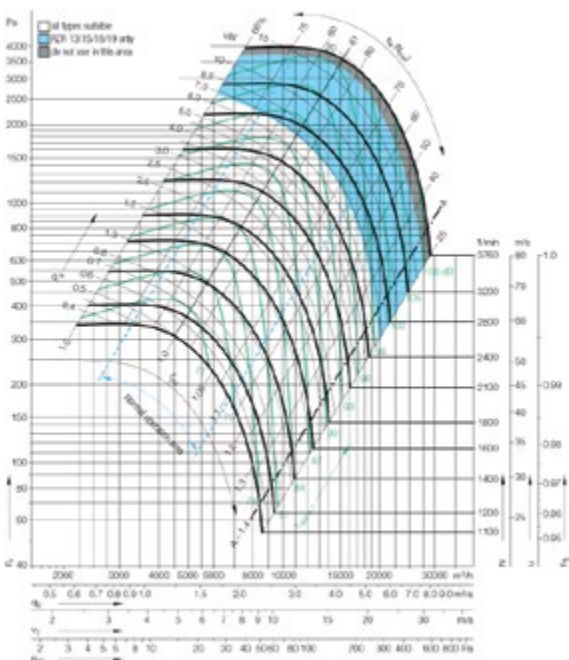

### RZR 0450

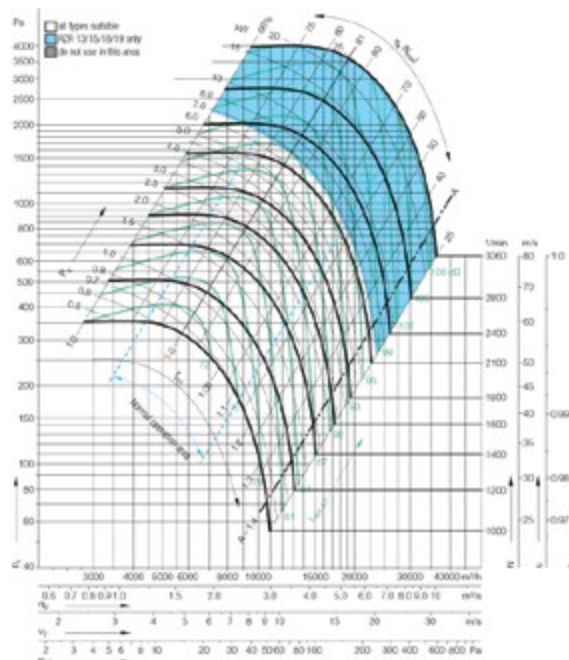

# Fan Rating Curves

## Aerofoil Fan Data

### RZR 0500

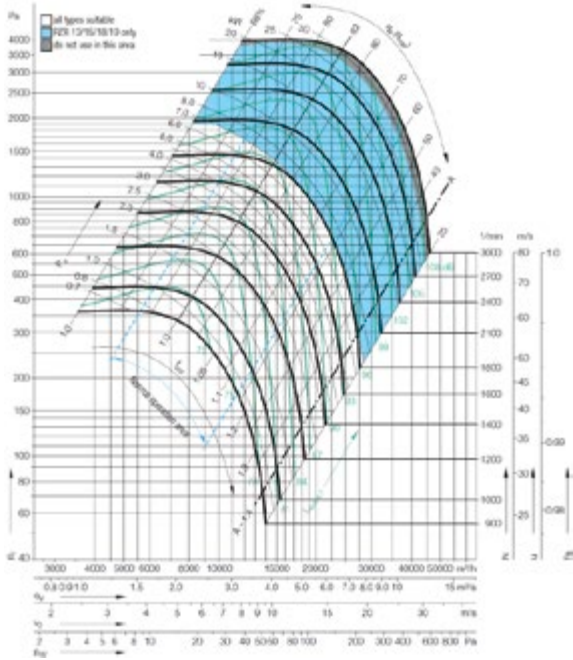

### RZR 0560

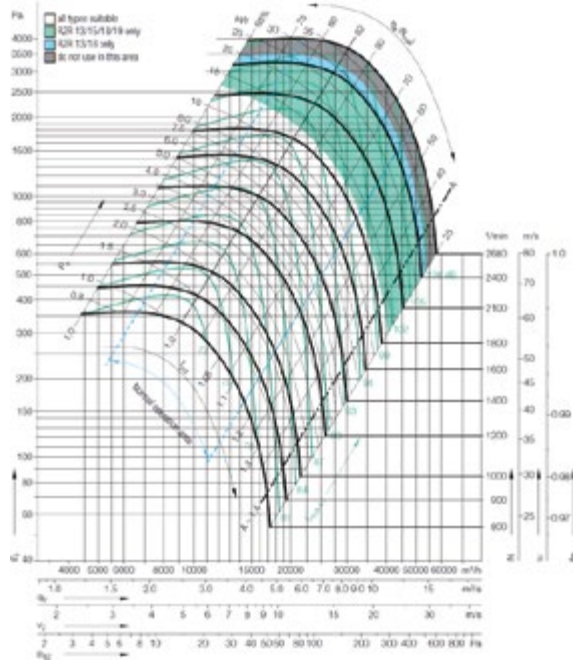

### RZR 0630

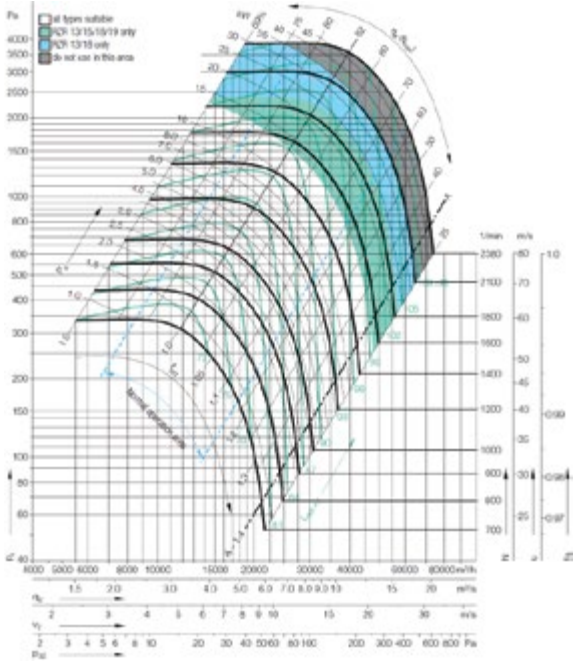

### RZR 0710

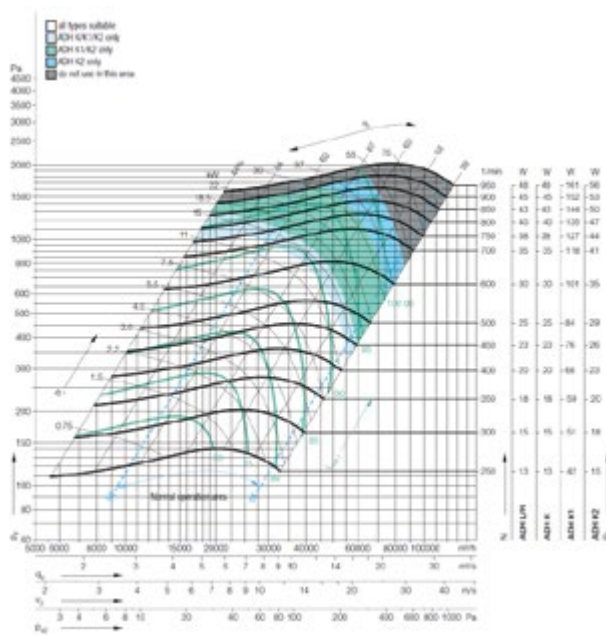

# Fan Rating Curves

## Aerofoil Fan Data

### RZR 0800

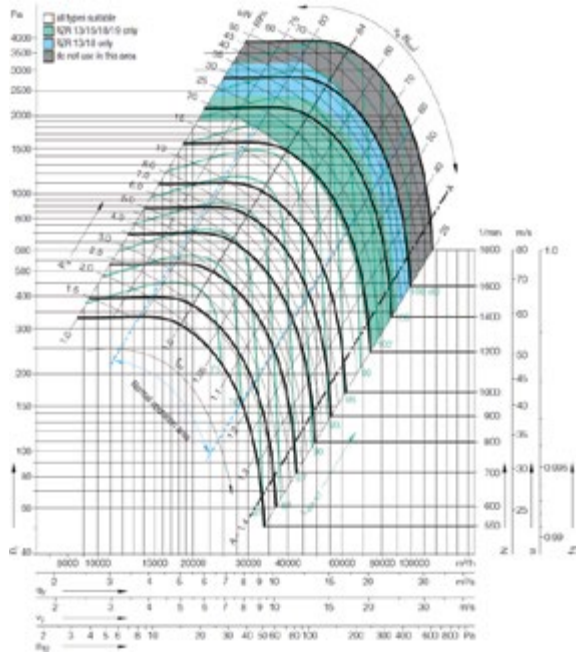

### RZR 0900

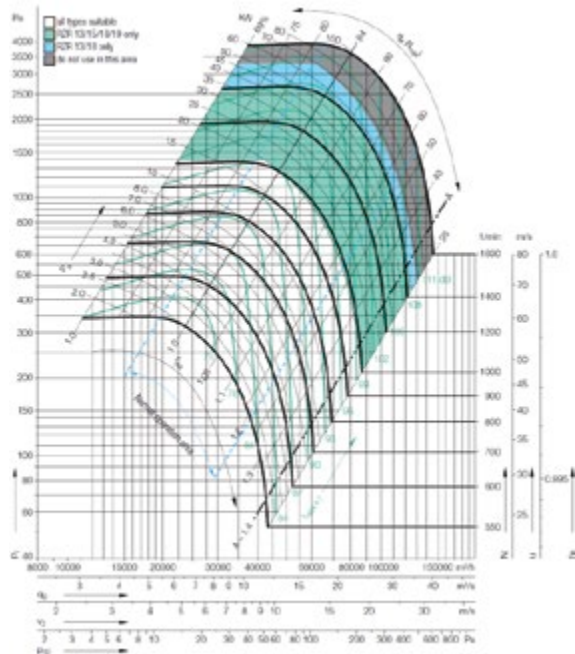

### RZR 1000

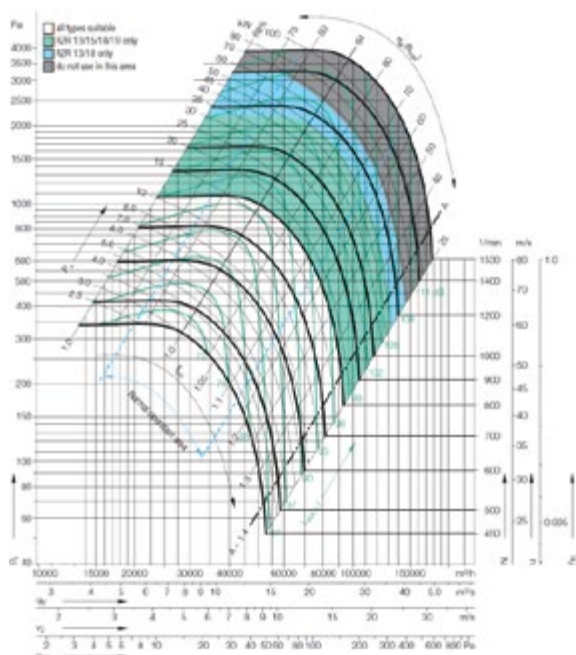

# Fan And Motor Arrangement

Forward Curved Fans [ADH]	
Fan Model	Maximum Motor Power [kW]
0160	3
0180	3
0200	4
0225	4
0250	7.5
0280	11
0315	18.5
0355	22
0400	22
0450	30
0500	37
0560	45
0630	45
0710	55
0800	55
0900	75
1000	75

Table - 10

Forward Curved Fans [AT]	
Fan Model	Maximum Motor Power [kW]
7/7	3
9/7	3
9/9	3
10/8	3
10/10	4
12/9	5.5
12/12	5.5
15/11	5.5
15/15	5.5
18/13	7.5
18/18	7.5

Table - 11

# Fan And Motor Arrangement

Backward Curved Fans [RDH]	
Fan Model	Maximum Motor Power [kW]
0180	3
0200	3
0225	4
0250	5.5
0280	7.5
0315	11
0355	15
0400	22
0450	30
0500	37
0560	37
0630	45
0710	55
0800	55
0900	75
1000	75

Table - 12

Aerofoil Fans [RZR]	
Fan Model	Maximum Motor Power [kW]
0200	7.5
0225	7.5
0250	7.5
0280	11
0315	11
0355	11
0400	30
0450	30
0500	30
0560	37
0630	37
0710	55
0800	55
0900	75
1000	75

Table - 13

# Air Handling Unit Installation Instructions

Air handling units are generally damaged during transportation and loading / unloading, especially when being lifted by a crane. Small units can be transported by hand-powered pallet truck or by forklift truck.

## WARNING:

Always use the lifting holes on the base frame to lift the unit by a crane. Never lift the units by coil connections or by any other protrusions. While hoisting or lowering, proper lifting equipment (slings and spreaders properly selected on the ground of the size and weight of the section) should be used not to damage the unit. Ensure that slings do not damage the unit casing and protrusions such as coil pipe connections, door handles, drain connections etc. Safety precautions should also be taken not to tilt and not to drop the unit.

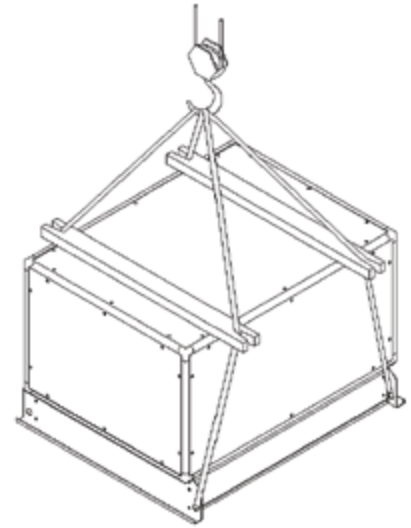

Fig. 1: Typical lifting equipment

## WARNING:

Units must be stored in rooms where the ambient temperature is within the range of  $-20^{\circ}\text{C}$  and  $+40^{\circ}\text{C}$  and relative humidity not exceeding 80%. Dust, gases and caustic vapors, chemical substances which have corrosive effect on the casing and components should not have access to the units.

During final installation the requirements of EN 60204-1 do apply.

Before manufacturing the air handling unit, the client should check the conditions at site to ensure that access routes are adequate for both size and weight of the unit sections. Air handling unit installation areas should also be checked. There should be sufficient space around the unit for servicing, maintenance and piping connections. Further, it must be ensure that the base is high enough from the floor to allow the condensate drain with necessary water trap.

## WARNING:

Air handling units should be installed on a rigid and level surface. Correct alignment of the sections is essential to maintain a satisfactory airtight enclosure and to avoid distortion to the casing and components. If the air handling unit is to be installed in a place where low vibration and noise is required such as hotels, hospitals etc. it is recommended to install the unit on a floating concrete base, around which is filled with expanded polystyrene.

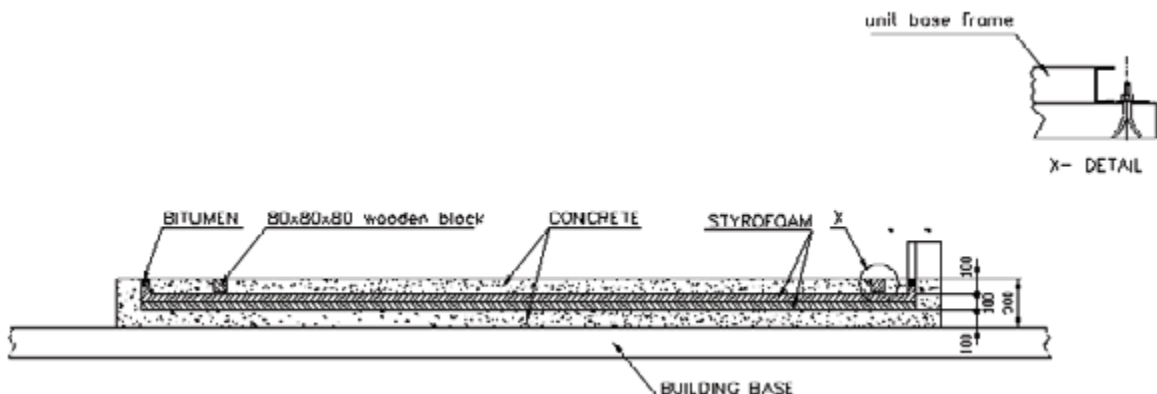

Fig. 2: Typical AHU concrete base

## Connection Of Sections

First of all, transport the unit sections to the place where the unit will be installed. Check the sealing strips for any damage. Replace the strips if there is any damage. The order in which the individual sections are assembled can be determined from assembly drawings and by following identification labels on each section. In order to reduce vibration, suitable anti-vibration strips may be placed under the base frame. To connect the sections, follow the instructions below.

### Pent a Post Air Handling Units

Once all sections are located in their place in the order they will be assembled, align the sections for air tightness and to easily fit the section connection bolts.

#### WARNING:

Do not use excessive forces to align the sections, because it may deform the aluminum framework and casing.

Sections are locked together by special connection parts, bolts, and nuts. Section connection parts are mounted on the unit sections, bolts and nuts are fitted on the connection pieces.

First attach the base frame connection bolts on the base frame, and then section connection bolts and tighten the bolts gradually starting from the base frame.

### Cold Bridge Free Air Handling Units

Cold bridge free air handling unit sections are connected to each other through the holes on the facing surfaces of the sections and through the holes on the base frame, by means of bolts and nuts supplied within the unit. First attach the base frame connection bolts on the base frame, and then section connection bolts and tighten the bolts gradually starting from the base frame. And then fit the intermediate cover lids.

## CONNECTIONS

### Ducting Connections

Return air, fresh air, exhaust air and supply air should be connected to the unit by flexible duct connectors. Air tightness should be maintained to achieve required air flow conditions. Poor ductwork connections to the unit and incorrect size, shape and arrangement of ductwork fittings can change airflow conditions.



Sealing Strips



Base Frame Connection



Section Connection

## Free Outlet Conditions

Discharging a centrifugal fan directly to atmosphere [Fig.3] is an inefficient method of discharge. It can be improved by the addition of a short duct length coupled to the fan outlet [Fig.4] or by the use of an expansion section [Fig.5] allowing the air to become less turbulent before being discharged. This is particularly important when grills or diffusers are being used at the discharge point as the manufacturers loss figures are based on a laminar flow air stream and turbulent air increases the losses.

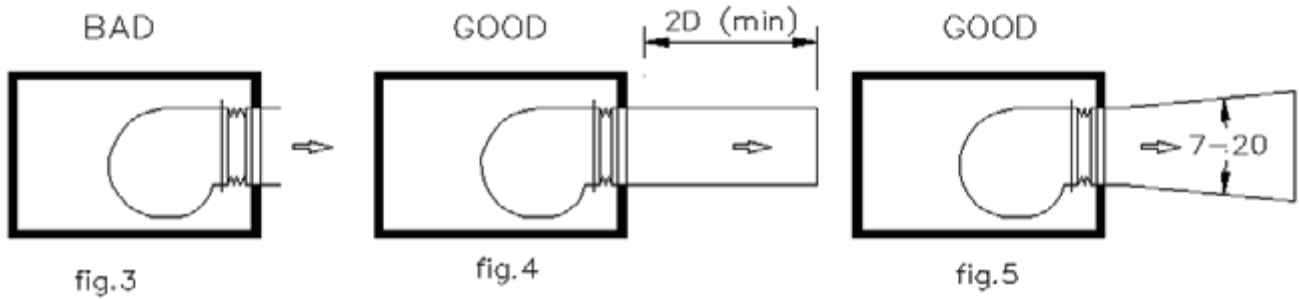

## Ducted Outlet Conditions

With the outlet connected to the discharge duct by a flexible connector, which is desirable for noise and vibration isolation, it is important that the connector is correctly fitted. The fan outlet and the duct should not be misaligned [Fig.6] nor should the flexible connector be allowed to concertina. A smooth passage of air is desirable at all times. [Fig.7]

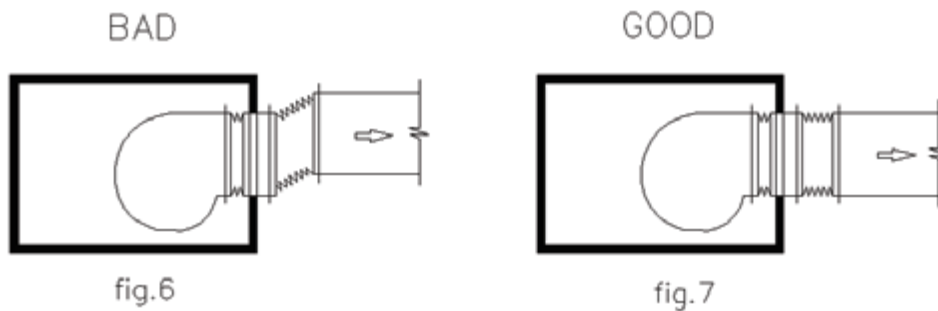

When discharging into a duct of larger cross-sectional area than the fan outlet, an expansion section with an included angle of  $7-20^\circ$  should be used. [Fig.8] The ideal configuration is with parallel length of ducting prior to the expansion section, allowing the air to become less turbulent before expanding. [Fig.9] The fan should never discharge directly into a duct with larger cross-section. [Fig.10]

The same criteria apply when discharging into a duct of smaller cross-sectional area than the fan outlet. A ducting section with an included angle of up to  $45^\circ$  should be used. Losses will again be minimized if a parallel section of ducting is used prior to the reducing section. [Fig.11] To achieve ideal conditions the length of parallel ducting in both cases should be equal to 8 impeller diameters. However parallel ducting of considerably shorter lengths can be used to advantage.

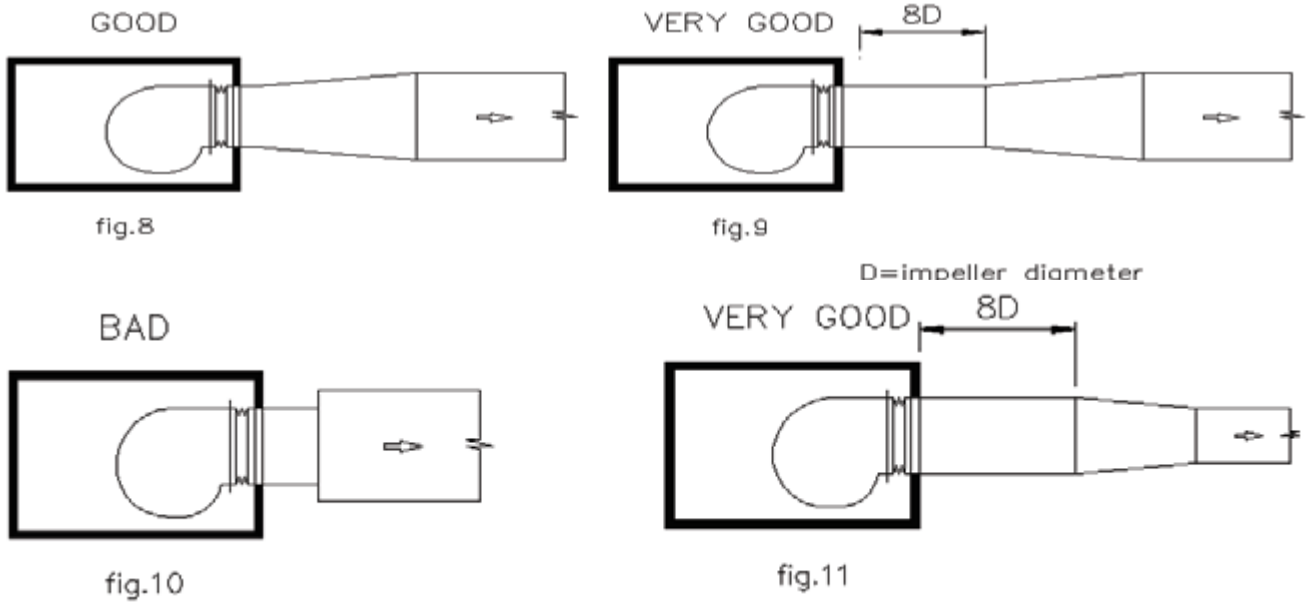

Extremely high losses occur when attempts are made to change the direction of the airflow close to the fan discharge. If this is necessary the installation should be carried out as in (Fig.12) and even as in (Fig.13) A better solution is to have a parallel section of ducting prior to changing direction and it should be as long as can be accommodated. (Fig.14)

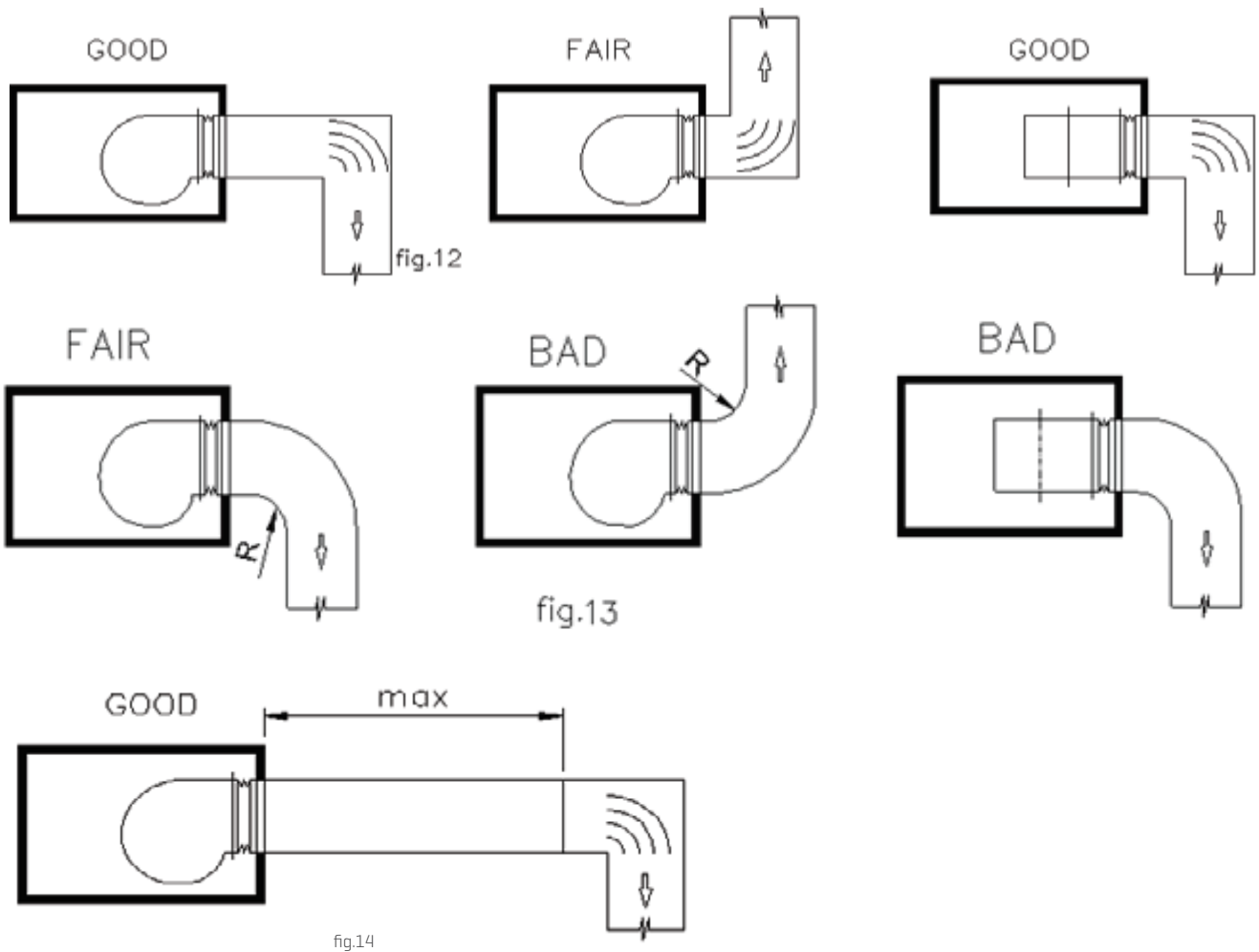

## Piping Connections

Coils should be piped in counter flow arrangement to achieve required capacity. This arrangement requires that the entering heating or cooling fluid contacts the air leaving the coil. Water heating and cooling coils should be arranged with inlet connection at the lowest level on one side of the coil near downstream and water outlet connection on the same side but at high level near the upstream. This arrangement drives any air in the system into the upper part of the coil, where a manual air release valve should be fitted.

All coils connecting piping should be independently supported not to impose strain on the coil connections or circuitry. All coils connecting piping should be thermally insulated

### WARNING:

Use a pipe wrench to restrain the pipe connections of the coil when tightening the external pipe connections.

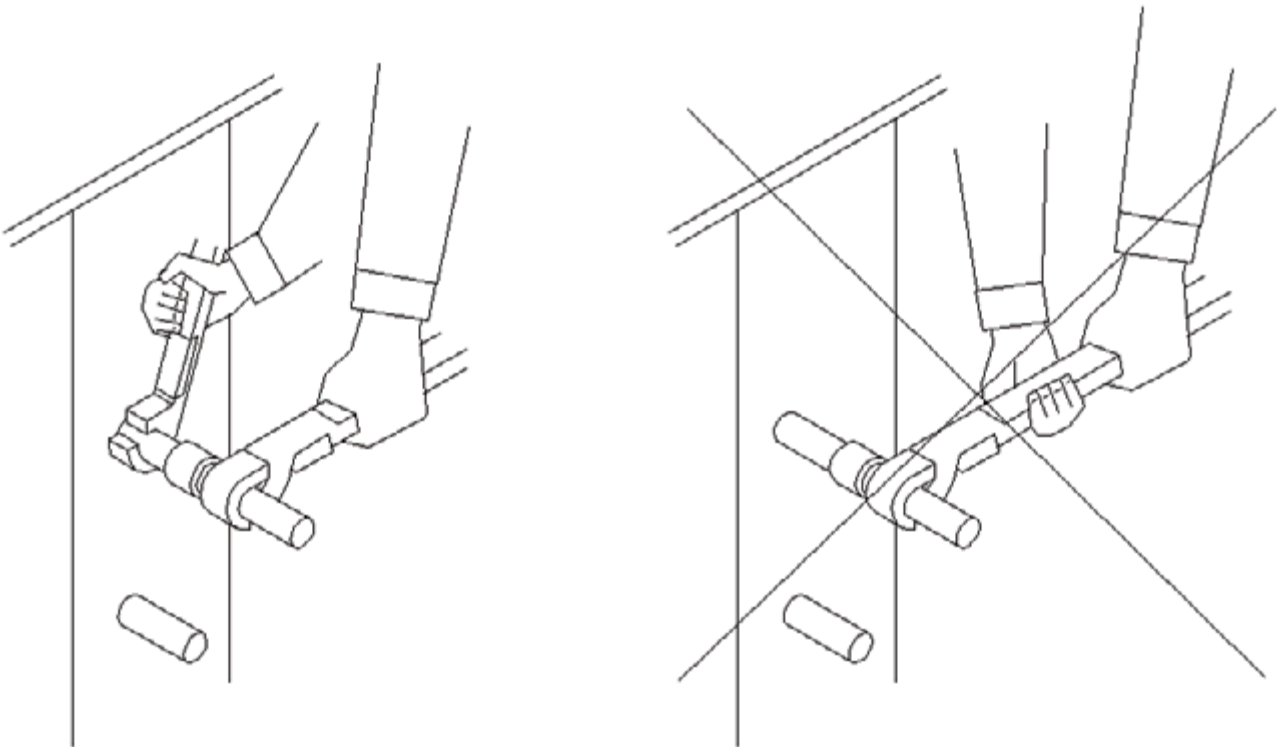

## Condensate Drain Lines

Moisture condensed out of the airstreams on cooling / dehumidifying coils should be drained out of the unit, to prevent water damage in the air handling unit and ductwork system. Following precautions should be observed in piping of condensate drain lines.

- Condensate pipe connections to drain pan should not be less than the bore size of the pan outlet connection.
- A union or pipe coupling should be fitted at the pipe connections to the pan to permit easy disconnection to clean any dirt sediments.
- The siphon (for positive and negative pressure applications) sent by the unit separately should be assembled according to its own installation instructions in the package.
- If the drain pipe is to be long, drain line should be pitched with a gradient not less than 1 in 50.

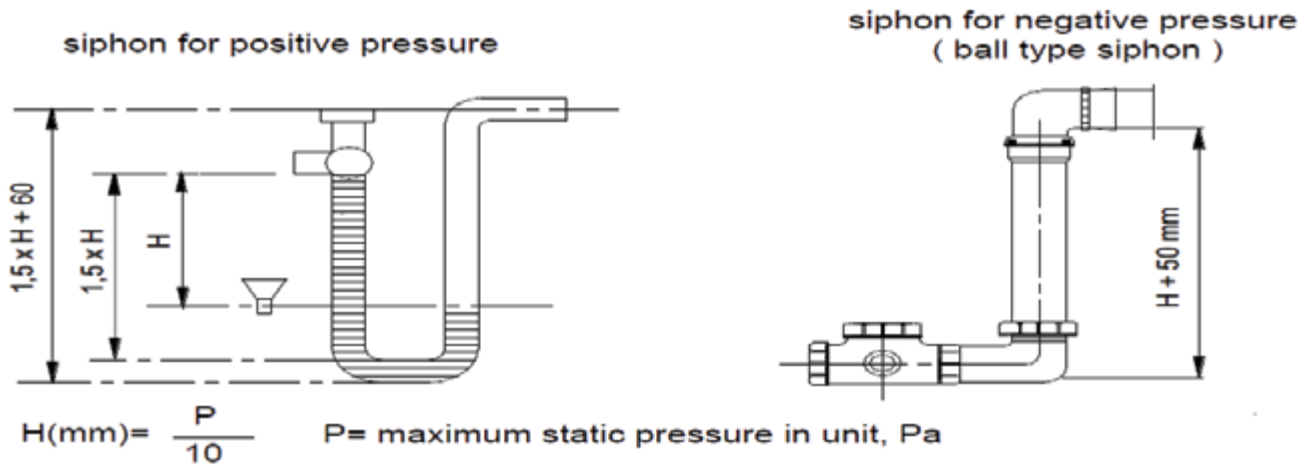

## Electrical Connections

Electric motor, starters, interconnecting cabling and any associated controls should be properly designed and selected to be suitable for the driven equipment or other electrical apparatus, to be safe and to comply with the requirements of Electricity Supply Authority. In case of the humidifier and frequency converter applications their own installation manuals should be used. For the other equipment the installation instructions and the wiring diagrams which stuck in the terminal box should be followed.

The equipment in the unit except lighting operate with 400V, 3Ph, 50Hz electric supply. Standard lighting equipment operates with 230V, 1Ph, 50Hz electric supply. Starter for centrifugal fans in the air handling units for single speed motors driving through V-belts are normally of the direct-on-line type. However the customer or Electric Supply Authority may require motors above 3kW to be operated by a star-delta starter, to reduce starting current.

### CAUTION:

To avoid the electric heater keep on running while the fan is not rotating, the wiring should be done similar to diagram given below:

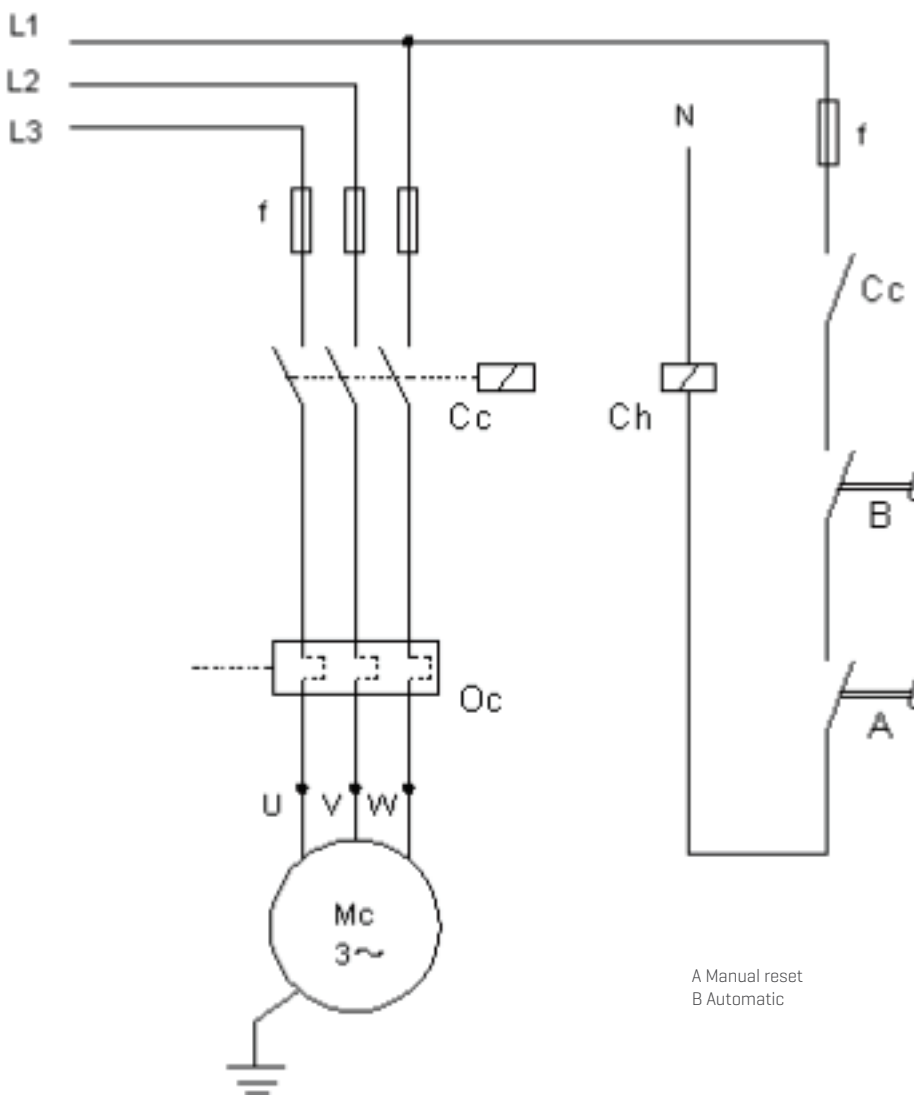

## WARNING:

Electrical installation and wiring works should be carried out by qualified and competent electricians, in accordance with all international, national and local regulations.

- Thermal overload relay setting

a) Direct-on-line starting: The thermal overload relay should preferably be set to the motor full load current shown on the motor rating plate.

b) Star-Delta starting: The thermal overload relay should preferably be set to the 0.58 x motor full load shown on the motor rating plate.

After thermal overload relay settings is done it should be checked that thermal overload relay works properly at normal operating conditions, by operating motor on two phases.

Motor terminal markings

- The terminal markings of motors conform to the international standards. Stator terminals are marked, U.V.W and the neutral terminal N.

- Please check data on the rating plate. The voltage marked on the rating plate must be in agreement with the mains voltage.

The terminal board is normally equipped with 6 terminals. Details concerning the connection are given on the inside cover of the terminal box and / or on a diagram placed inside by the manufacturer.

- Specifications require that all motors to be earthen properly. Special terminal in the terminal box should be used for this purpose.

- To avoid the danger of overloading and operation on two phases, the motors should be protected either with fuses and thermal/thermo magnetic switches or electronic circuits. [See page 37]

- If the electric heater will be used, electrical connections should be done according to the information on the heater label.

The unit must be installed with a disconnecting device and over current relay on the site if it has not already equipped.

The supply cable cross-section-area and length should be selected according to the;

- Motor, lighting, electrical heater, etc power input and electrical supply

## NOTE:

All power and electrical supply values have indicated on the name plate of the unit and/or name plate of the equipment except the lighting. Electrical Supply of the lighting is 230V, 1Ph, 50Hz and the power input of the lighting is 100W as standard. Cable specification from the terminal box to lighting is H05V-K 2x0.75

- Cable installation conditions

- International standards, local rules, regulations and standards and requirements of Electric Supply Authority.

## Converter-fed Operation of Motors

When driving motors by a frequency converter, the following must be observed:

- The fan motor must be suitable for operation with a frequency converter.
- Rated speed of motor given on the rating plate should not be exceeded.
- Maximum speed and maximum installed power values for fans given on pages 33 - 34 must not be exceeded.
- Fan motor must be protected by PTC thermistor against overload and overheating.
- Frequency converter must be over speed protected.
- Motor PTC thermistor must be wired to the frequency converter by shielded leads.
- Assembly instructions of motor and frequency converter manufacturers must be referred.
- If the operating point of the fan will exceed the design operating point of the fan, there is a risk of motor to overload and overheat. Please consult to Gmcair HVAC Systems, if the design operating point of the fan will be exceeded.

### WARNING:

At very low speeds for converter-fed operation, there is a risk of operation at mechanical resonance frequency. So, operation of motor at speeds lower than 300 rpm is not recommended.

Programming, first operation and periodic control of frequency converters should be made by qualified personnel, according to manufacturer's instructions.

a-Direct-on line starter with control circuit

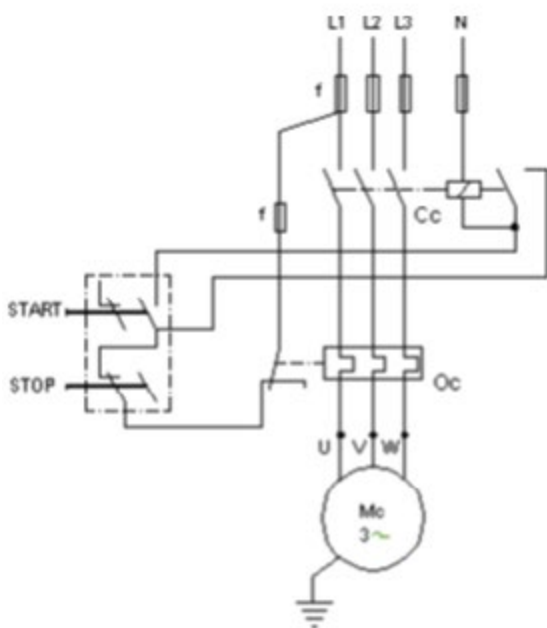

b-Star-delta starter

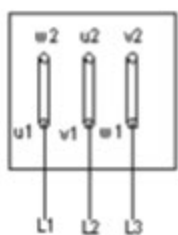
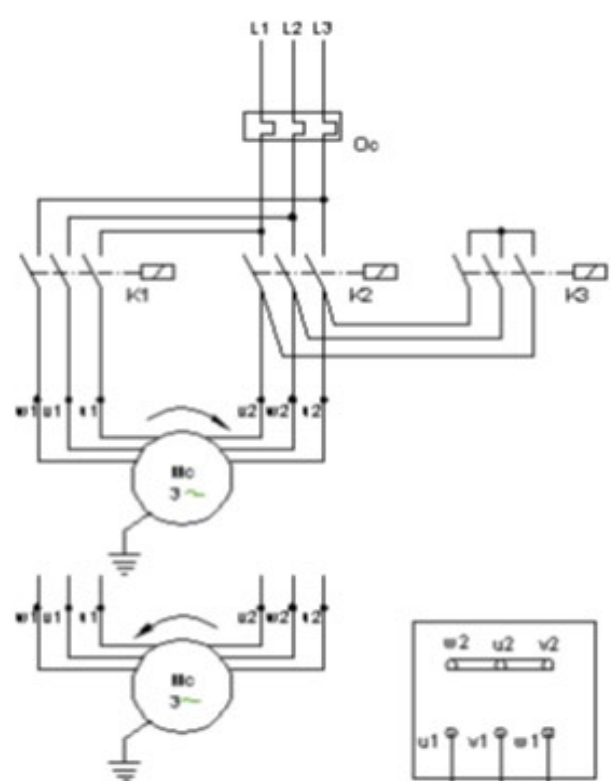

DELTA CONNECTION

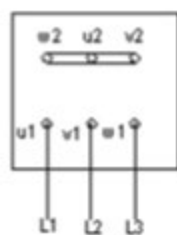

STAR CONNECTION

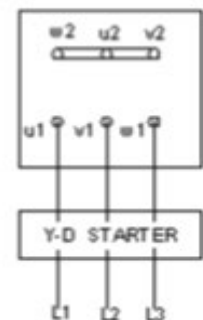

Y-D STARTER

### c-Dahlander switch ( 2 speed )

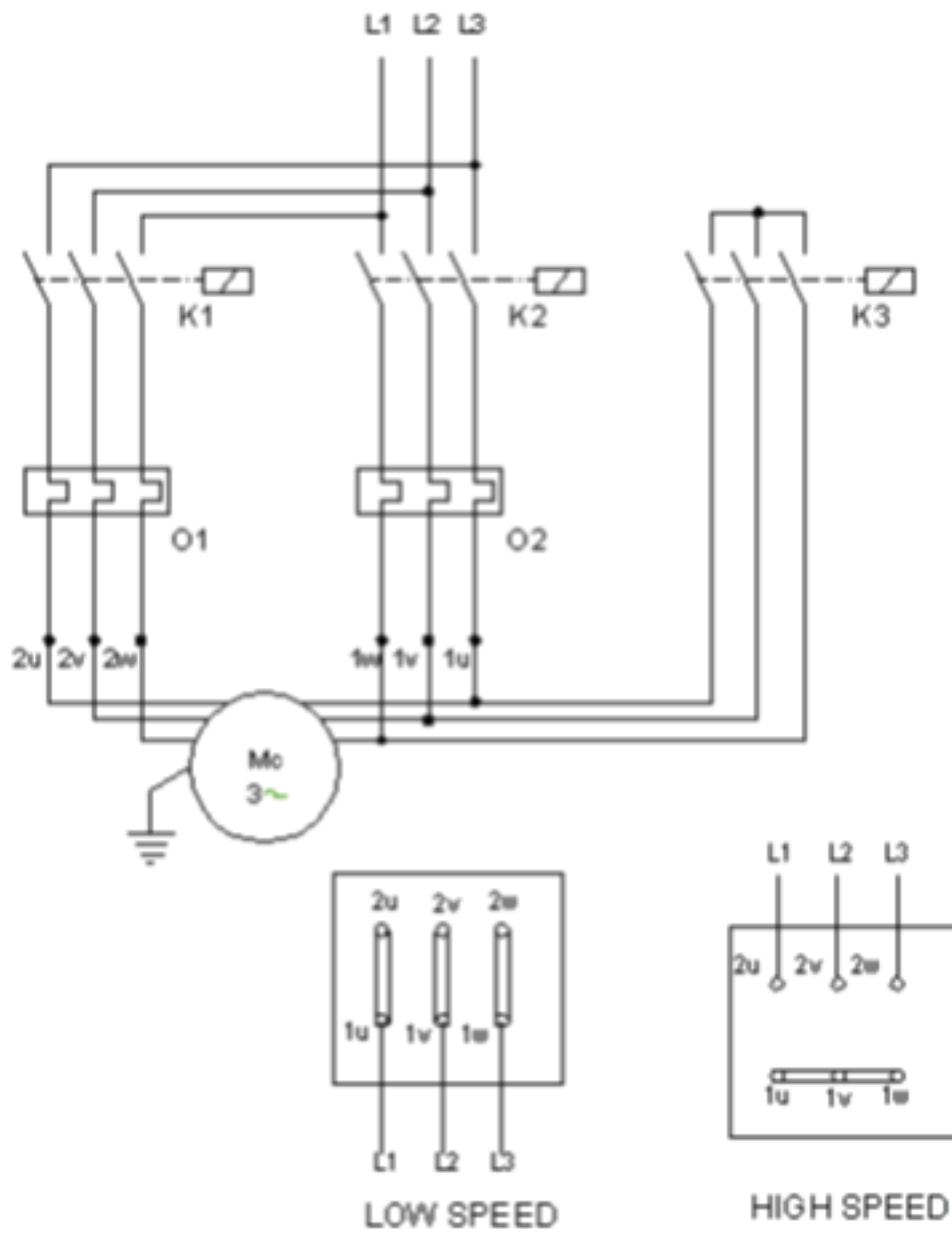

d-Pole changer with two separate windings ( 2 speed )

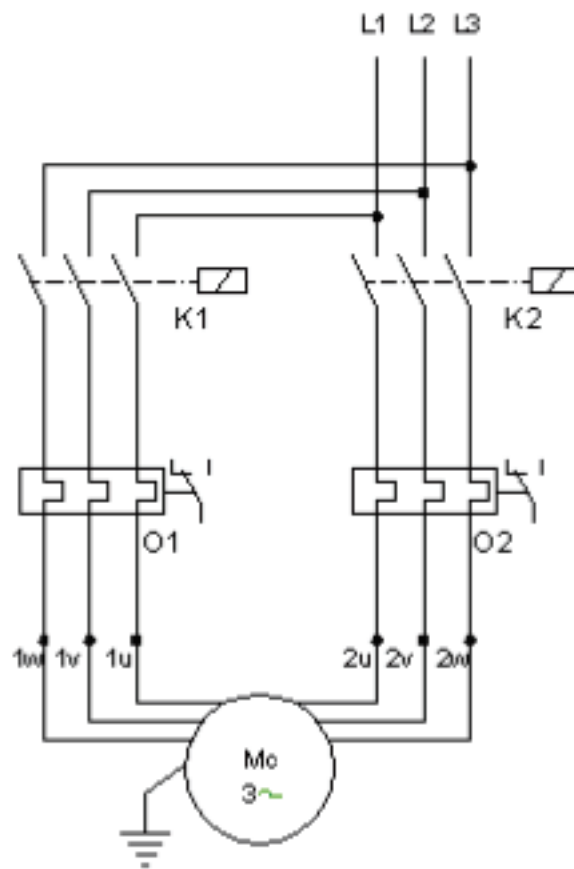

NOTES





---

 İnönü Mah, Gebze Plastikçiler OSB, 93. Sk, No:3 Tuzla - Gebze / İSTANBUL

 +90 262 502 16 46       +90 262 502 16 45

 [info@gmcair.com](mailto:info@gmcair.com)

[www.gmcair.com](http://www.gmcair.com)