

Project:
Tag:
Engineer:
Contractor:
Date:

LINEAR SLOT DIFFUSERS

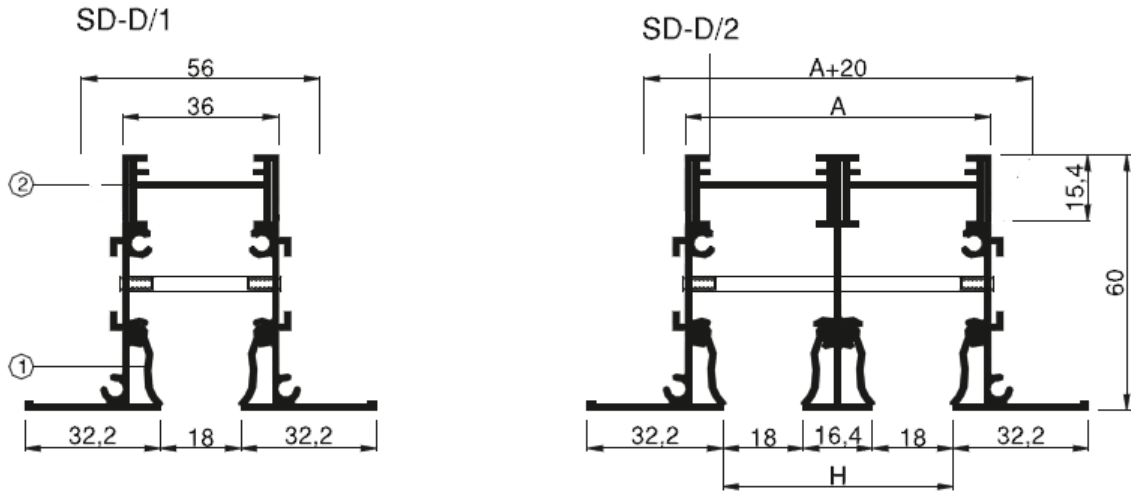

① Air supply direction blade ② Volume damper

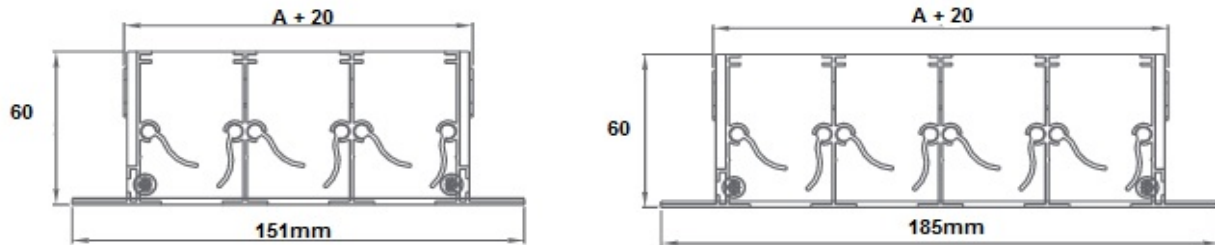

<u>Number of Slots</u>	1S	2S	3S	4S
<u>H (mm)</u>	18mm	52,4mm	86,8mm	121,2mm
<u>A (mm)</u>	36mm	71mm	105mm	137mm
<u>Box Neck Size (mm)</u>	56mm	91mm	125mm	157mm

AVAILABLE FINISHES

STANDART FINISH:

01 WHITE (RAL 9016)

OPTIONAL FINISH (NO EXTRA CHARGE):

06 MILL FINISH 02 WHITE (RAL 9010)

OPTIONAL FINISH (ADDITIONAL CHARGE):

- 03 SATIN SILVER 07 CUSTOM COLOR/ SETUP CHARGE
 04 ANODIZED 08 RAL...../ SETUP CHARGE
 05 BLACK

- SD-D : Supply slot diffuser with damper and deflector blades
 SD-T : Return slot diffuser with damper
 SD-C : Curved Supply / Return
 SD-4W: 4-way Slot Diffuser

As part of our continuous improvement program, we reserve the right to make further improvements without notice.

Date submitted: