

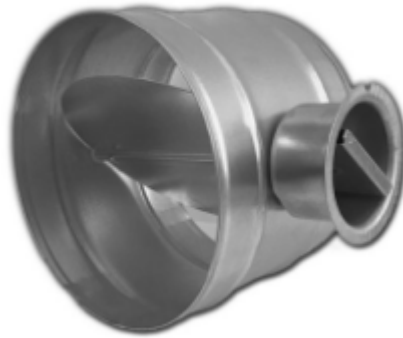

**Circular Control Damper
CCD**



DESCRIPTION:

Volume Control damper is widely used in heating, ventilation and air-conditioning applications (HVAC Damper) in order to maintain or control the air volume inside the duct. These dampers facilitate the air flow to each zone and each room to be controlled during testing & commissioning. The blades may be parallel or opposed type depending on the requirement.

Volume control damper can be mounted either horizontally or vertically. However, care should be taken to mount the damper, by orienting the blades in the direction of the desired airflow. Gmcair provides several types of volume control dampers to choose from.

Circular Volume Control Damper are commonly used in plenum mouths where flexible ducts are connected. They are also used in round ducts.

CCD-R : Galvanised sheet metal quadrant with hand locking device and blade position indicator

CCD-RF : Galvanised sheet metal quadrant with hand locking device and blade position indicator with flans

CCD-L : Galvanised sheet metal quadrant with hand locking device and blade position indicator

CCD-K : Galvanised sheet metal quadrant with hand locking device and blade position indicator

CCD-KC: Galvanised sheet metal quadrant with hand locking device and blade position indicator with rubber sealing

* Optional : Pvc quadrant with hand locking device

MATERIAL :

Galvanized Metal Sheet.

FUNCTION:

- Frame is constructed from high quality galvanized steel sheet. Joints are welded and protected by aluminium spray coating.
- Damper blade, which is fixed to the bearing pin, can be rotated in vertical plane from full open to full close.
- Bearing pin is coupled with hand locking quadrant with open and close marking. Hand locking quadrant frame is marked to show exact position of damper.
- Designed for use in heating, ventilating and air conditioning items.



STANDARD SIZES (mm):

TYPE CCD - AVAILABLE SIZES (mm)															
Ø NECK DIAMETER															
100	125	150	160	180	200	224	250	280	300	315	355	400	450	500	560
X	X	X	X	X	X	X	X	X	X	X	X	X	X	X	X

DRAWING

CCD-R

CCD-RF

imperial

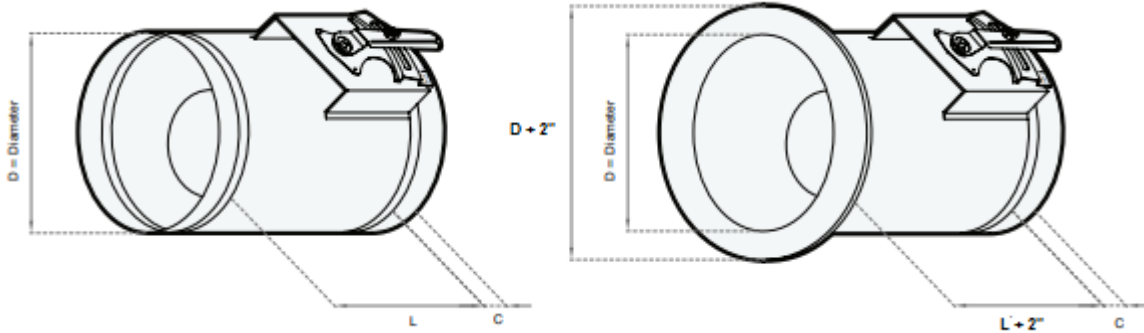

Metric

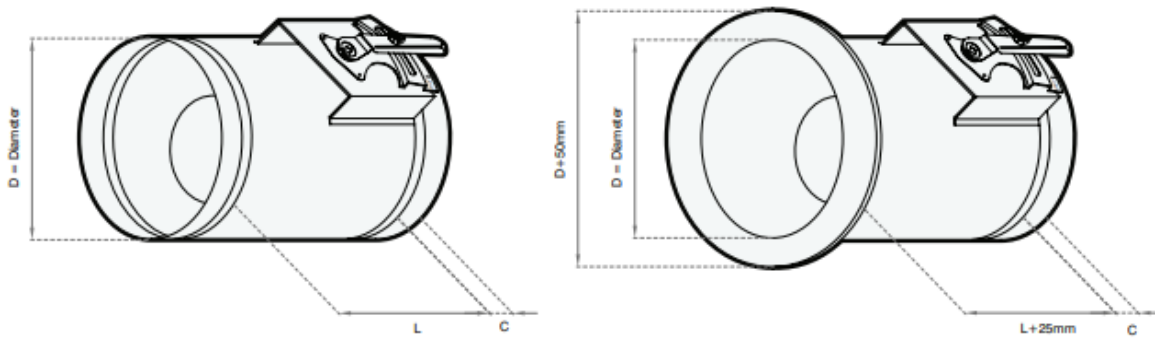

CCD-L

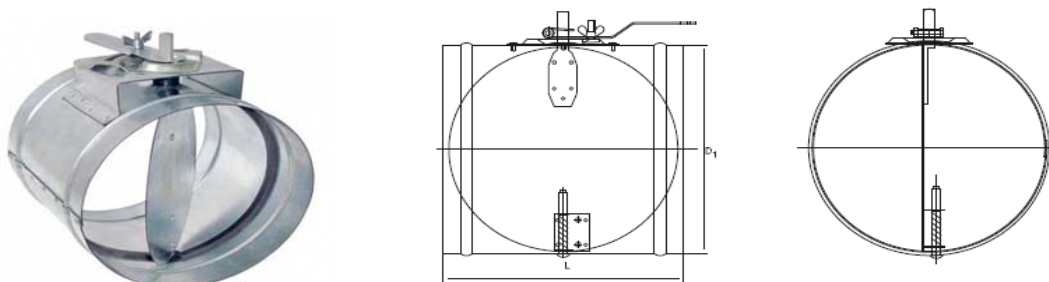



**CCD-K
Characteristics**

- The damper is designed with an internal blade, an actuator and locking screw.
- The damper blade can be adjusted on the actuator within a range of 0° to 90°.

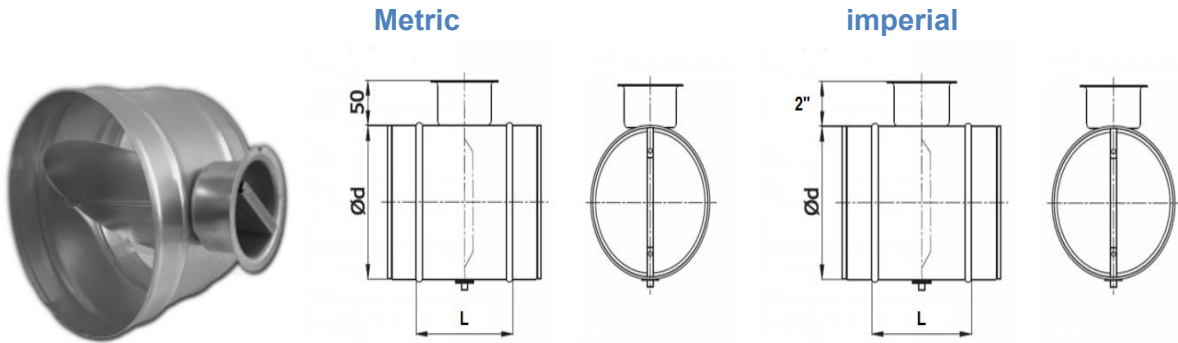

**CCD-KC
Characteristics**

- The damper is designed with an internal blade, an actuator and locking screw.
- The damper blade can be adjusted on the handle within a range of 0° to 90°.
- Sealing gaskets at each end and on the interior blade.

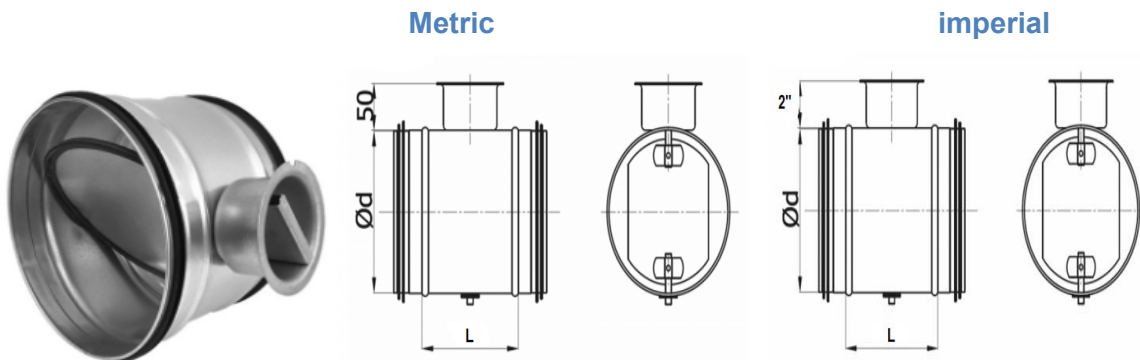

FUNCTION:

CONTROLLER - Hand Locking Device Types





SELECTION

Ø	Flow [m ³ /h]	V [m/s]	α = 15°		α = 30°		α = 45°		α = 60°	
			ΔPt [pa]	LW [dB]	ΔPt [pa]	LW [dB]	ΔPt [pa]	LW [dB]	ΔPt [pa]	LW [dB]
100	53	2	3	6	8	14	36	25	194	41
	105	4	12	25	34	33	145	44	774	59
	158	6	26	36	76	39	327	55	1742	62
	211	8	46	43	136	52	581	63	3098	78
	263	10	73	49	212	58	908	69	4840	84
	316	12	105	54	305	63	1307	73	6970	88
125	83	2	3	7	8	16	36	27	194	42
	167	4	12	26	34	35	145	46	774	61
	250	6	26	37	76	46	327	57	1742	72
	334	8	46	45	136	46	581	64	3098	72
	417	10	73	51	212	60	908	71	4840	85
	501	12	105	56	305	65	1307	75	6970	90
160	139	2	3	9	8	18	36	29	194	44
	277	4	12	28	34	37	145	48	774	63
	416	6	26	39	76	48	327	59	1742	74
	554	8	46	47	136	56	581	66	3098	82
	693	10	73	53	212	62	908	72	4840	88
	831	12	105	58	305	67	1307	77	6970	92
200	218	2	3	11	8	19	36	31	194	46
	436	4	12	30	34	38	145	50	774	65
	654	6	26	41	76	50	327	60	1742	76
	872	8	46	49	136	57	581	68	3098	84
	1091	10	73	55	212	63	908	74	4840	89
	1309	12	105	60	305	68	1307	79	6970	94
250	342	2	3	12	8	21	36	32	194	48
	684	4	12	31	34	40	145	51	774	66
	1027	6	26	43	76	51	327	62	1742	78
	1369	8	46	50	136	59	581	70	3098	85
	1711	10	73	57	212	65	908	76	4840	91
	2053	12	105	61	305	70	1307	81	6970	96
315	546	2	3	14	8	23	36	34	194	49
	1092	4	12	33	34	42	145	53	774	68
	1639	6	26	44	76	53	327	64	1742	79
	2185	8	46	52	136	61	581	72	3098	87
	2731	10	73	58	212	67	908	78	4840	93
	3277	12	105	63	305	72	1307	83	6970	98

Annotation

*Lw [dB] - Noise level

*ΔPt [pa] - Pressure loss

*V[m/s] - Air speed



Circular/Round Volume Control Damper Selection Graph

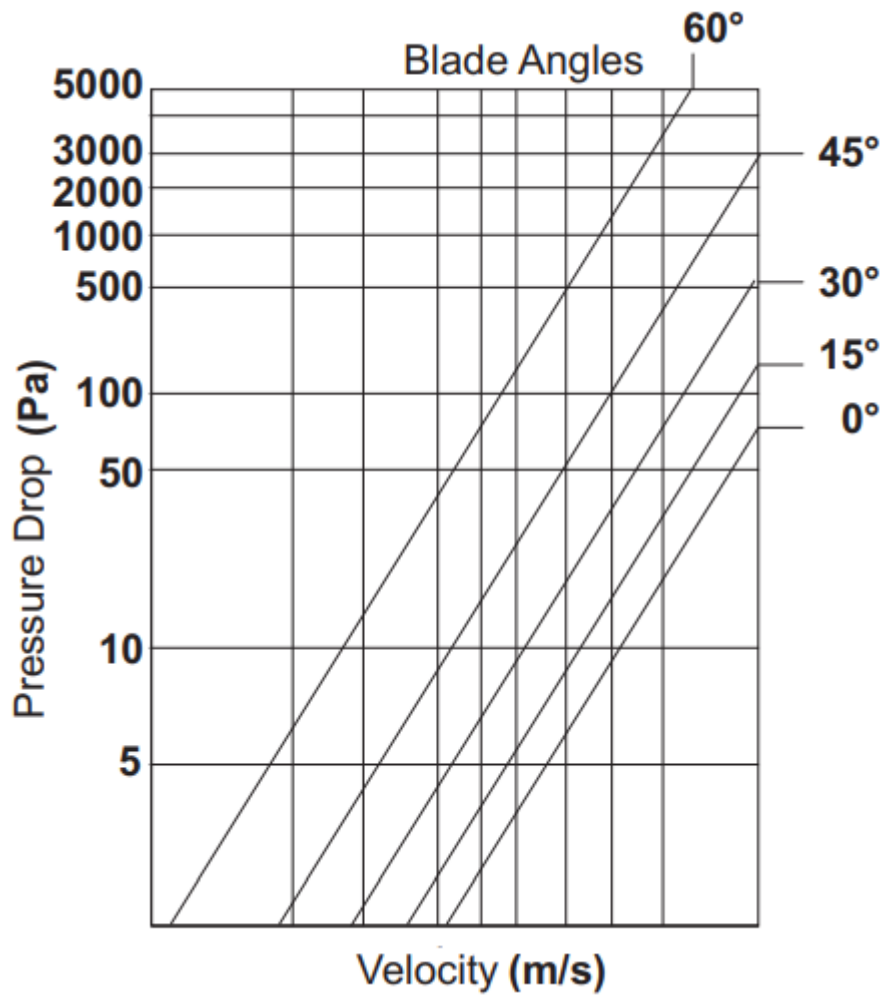



ORDER CODE:

CCD-	G	1	S	00	D 315
CCD-R CCD-RF CCD-L CCD-K CCD-KC					
G: Galvanized Metal Sheet (Standard) A: Aluminum (Optional)				00: No coating RAL----: Powder Coating	
Type-1 Type-2 Type-3 Type-4				S: Standard L: Requested Product Length (Special)	
				N: Neck Size D: Neck Diameter	