

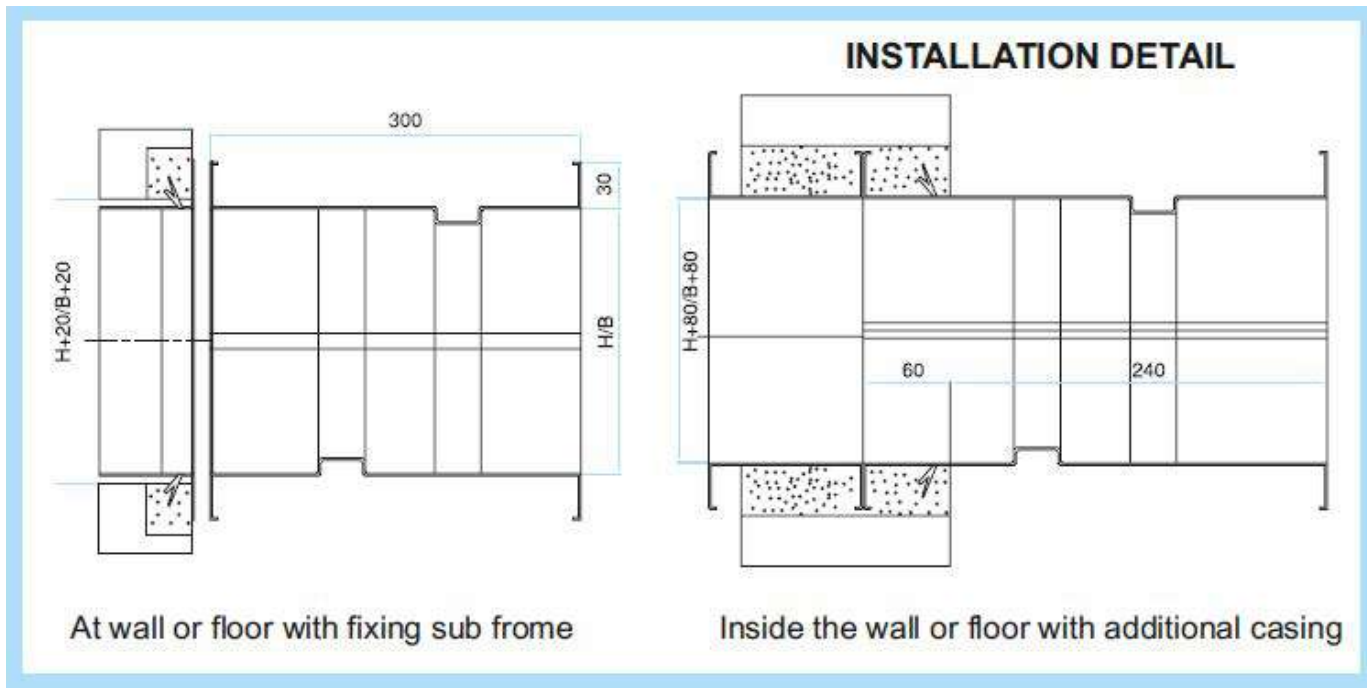

MODEL YD143

Prismatic Single Wing Fusible Link Fire Damper

Project:
Tag:
Engineer:
Contractor:
Date:

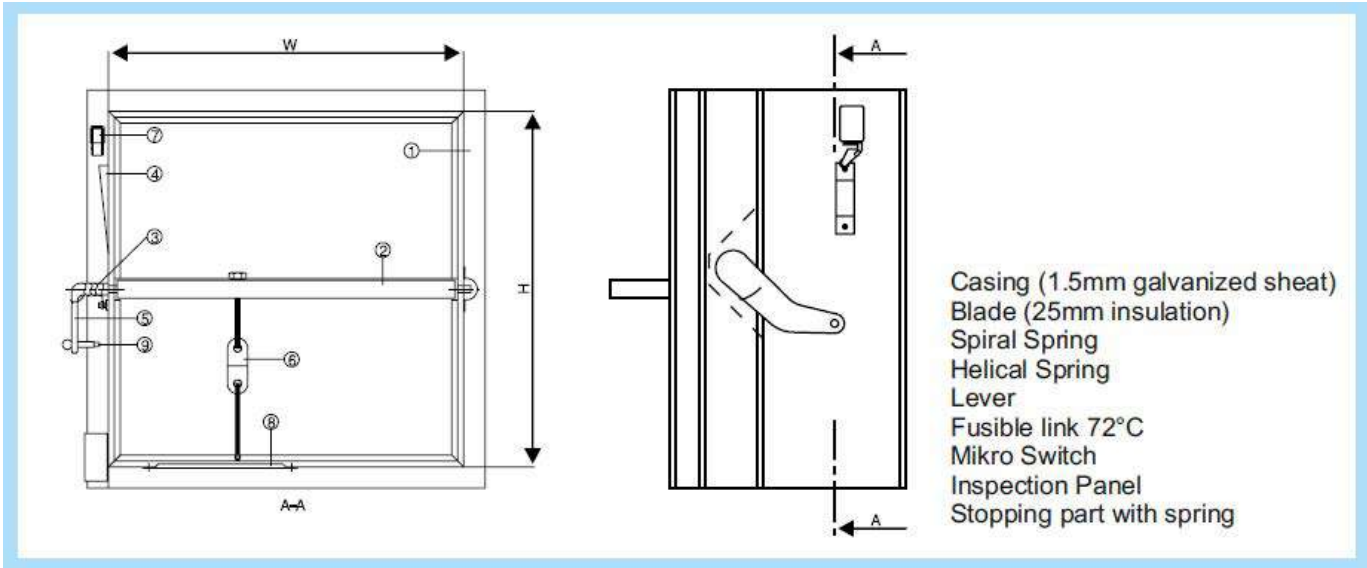

As part of our continuous improvement program, we reserve the right to make further improvements without notice.

			Date submitted:
--	--	--	-----------------