

Project:
Tag:
Engineer:
Contractor:
Date:



Submittal: RL

High Capacity Cylindrical Drum Extruded Aluminum

Models: RL Roto Louver - Standard Blades
 RL-DF Roto Louver - Dual Flow Blades
 RL-GO Roto Louver - With Gang Operator

Model: RL (Roto Louver - Standard Blades)

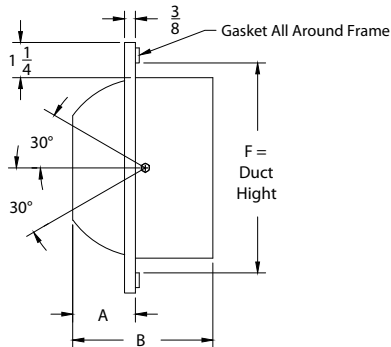

Model: RL-DF (Roto Louver - Dual Flow Blades)

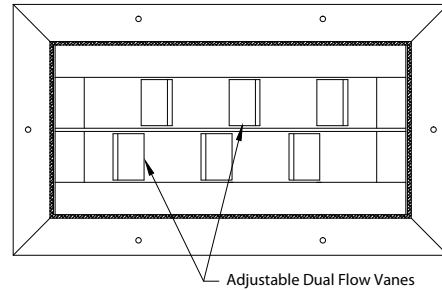

Model: RL-GO (Roto Louver - With Gang Operator)

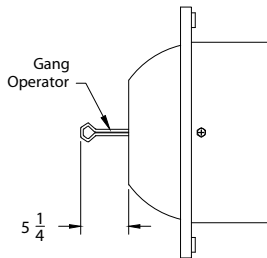

Available Listed Heights	6						10							12						15												
	9	12	18	24	30	36	48	60	20	25	30	35	40	50	60	70	20	25	30	35	40	50	60	70	15	20	25	30	40	50	60	70
Available Listed Widths	2	3	5	7	9	11	15	19	3	4	5	6	7	9	11	13	3	4	5	6	7	9	11	12	2	3	4	5	7	9	11	13
Number of Louvers	A						B							C						D												
	1 3/4						2 5/8							3						3 1/2												
	4 3/8						6 1/8							6 1/8						8												
	3 1/2						5 7/8							6 1/4						9 1/2												
	3						5							5						5												
	8 1/2						12 1/4							13 7/8						16 7/8												
	7						10 13/16							12 1/2						15 1/2												

Options: RL (Roto Louver - With Aluminum Damper)
 RL-DF (Roto Louver - With Aluminum Damper - Dual Flow)
 RL-GO (Roto Louver - With Aluminum Damper & Gang Operator)

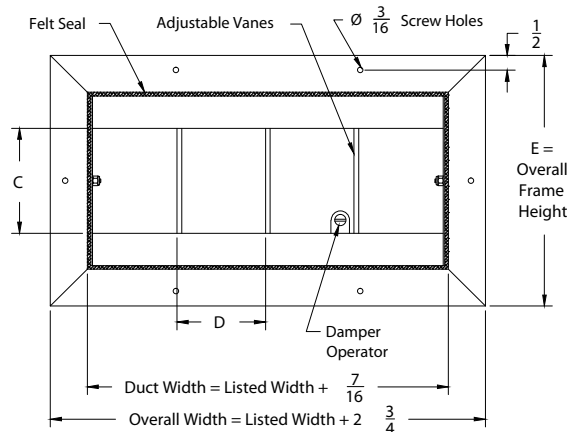
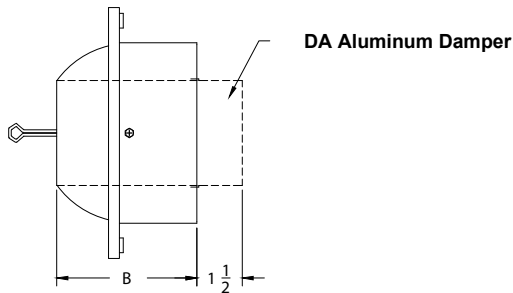

Notes: check if provided)

1. Available Finishes	2. Available Accessories	3. Available Options	4. Construction Details
Standard Finish: <input type="checkbox"/> 01 White <input type="checkbox"/> 02 Satin Silver <input type="checkbox"/> 04 Clear Anodized	(Shipped Attached) <input type="checkbox"/> DA Aluminum Damper.		<ul style="list-style-type: none"> Available Only in listed sizes.