



**Square 3 Cone Diffuser  
S3CD**



**DESCRIPTION:**

The Square Cone Diffuser (S3CD) features a highly engineered, aerodynamic backpan and cone assembly that creates a horizontal 360° radial air pattern. The S3CD promotes rapid mixing, temperature equalization, and velocity reduction with industry-leading low pressure drop and sound generation. Ideal for VAV applications with high turndown rates, the S3CD maintains a consistent, stable air pattern even as air volume is reduced, minimizing dumping and drafts.

**CONSTRUCTION:**

- Steel (S3CD)
- Aluminum (AS3CD)

**APPLICATION:**

The Square Cone Diffuser, or S3CD, is ideal for use in ceiling applications and is compatible with most standard ceiling styles.

**FINISHING:**

- Powder coated in RAL9010 colour as standard. Other colours on request

**INSTALLATION:**

- 24" x 24" T-bar lay-in

**ACCESSORIES:**

- D: Damper
- PB: Plenum Box



**STANDARD SIZES:**

TYPE S3CD - AVAILABLE SIZES (in)	
	FRAME SIZE-MODULE
Diameter	24" x 24"
6"	X
8"	X
10"	X
12"	X
14"	X

**TECHNICAL DRAWINGS:**

**24"x24" SQUARE 3 CONE CEILING DIFFUSER WITHOUT DAMPER**

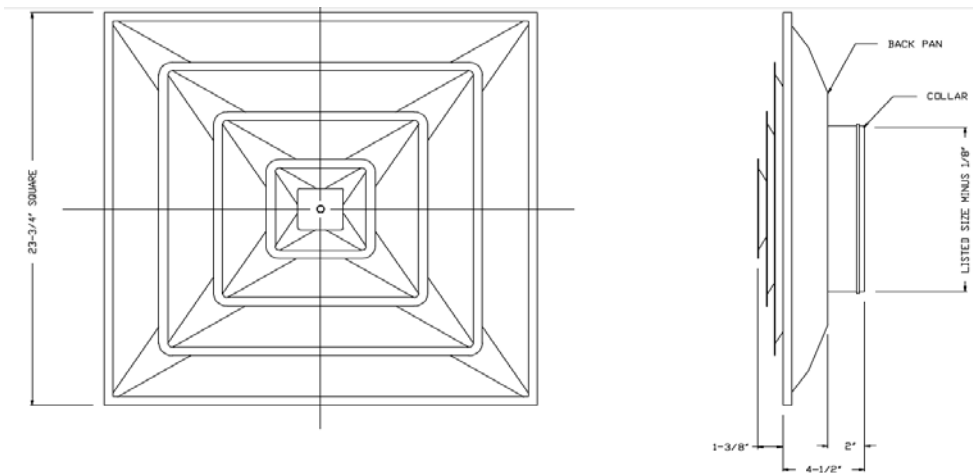

**24"x24" SQUARE 3 CONE CEILING DIFFUSER WITH DAMPER**

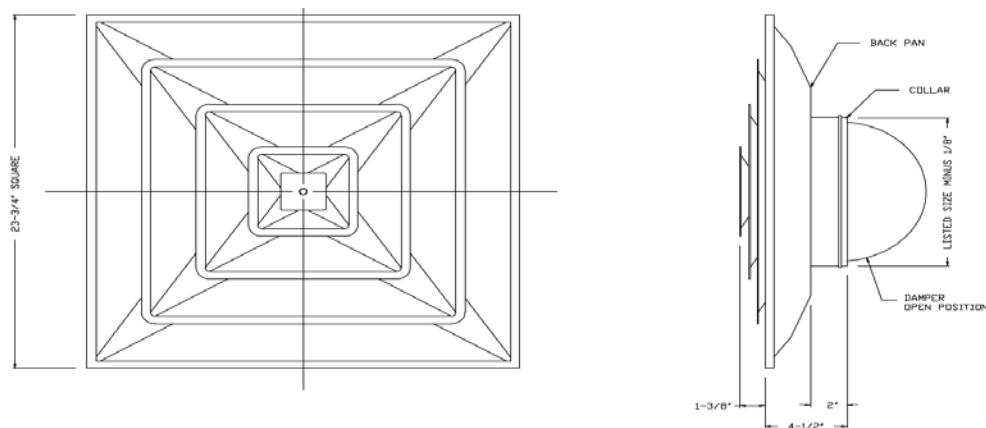



24"x24" SQUARE 3 CONE CEILING DIFFUSER WITH INSULATED

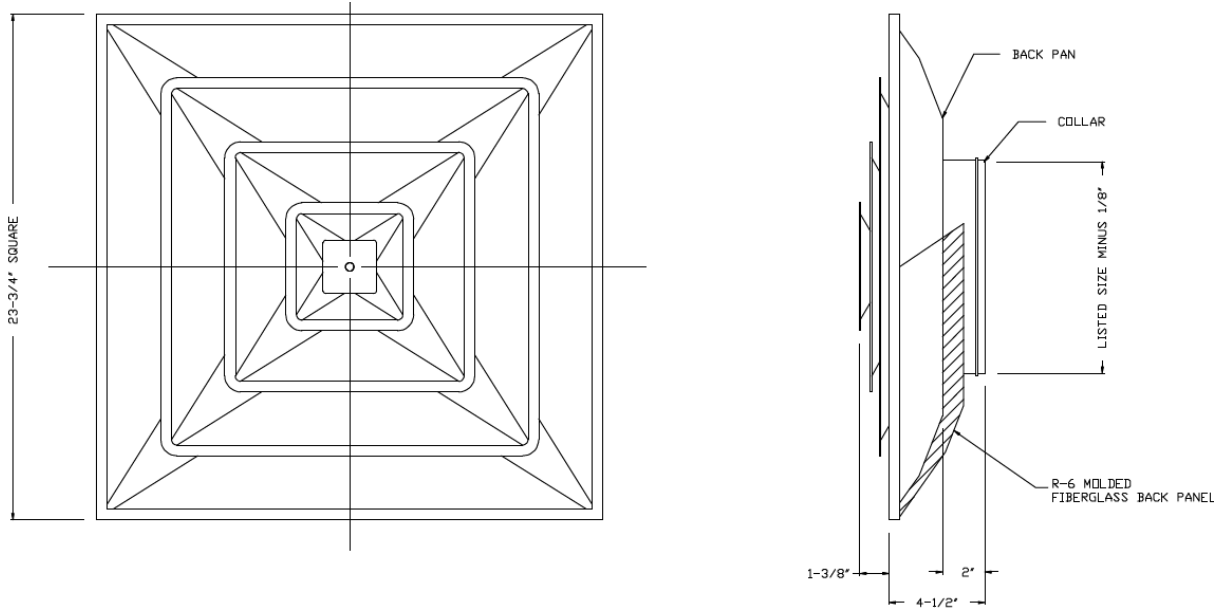

24"x24" SQUARE 3 CONE CEILING DIFFUSER WITH INSULATED WITH DAMPER

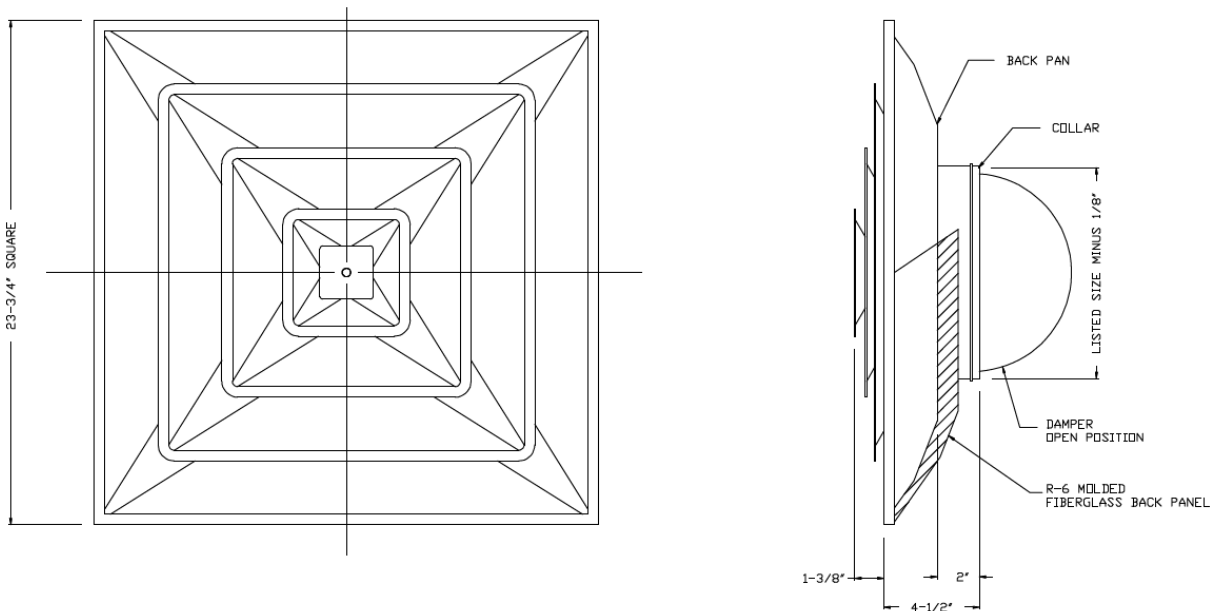



24"x24" SQUARE 3 CONE CEILING DIFFUSER PERFORMANCE DATA:

Model S3CD , S3CD-D , S3CD-R6 , S3CD-DR6

Panel Size	Neck Size	Area Ak	Inlet Velocity	400	500	600	700	800	900	1000	1200
24x24	6"	.196	CFM	80	100	120	135	155	175	195	235
			Ps	.014	.021	.031	.039	.051	.065	.081	.118
		.077	Throw	5	5	6	6	6	7	7	8
			NC	<15	<15	<15	<15	<15	16	18	23
24x24	8"	.349	CFM	140	175	210	245	280	315	350	420
			Ps	.016	.025	.036	.048	.063	.080	.099	.142
		.136	Throw	6	7	7	8	9	9	10	10
			NC	<15	<15	<15	<15	<15	18	21	26
24x24	10"	.545	CFM	220	275	325	380	435	490	545	655
			Ps	.019	.030	.042	.057	.075	.096	.118	.171
		.213	Throw	8	8	9	10	11	11	12	13
			NC	<15	<15	<15	<15	16	20	24	30
24x24	12"	.785	CFM	315	395	470	55	63	725	785	940
			Ps	.021	.033	.046	.063	.083	.104	.129	.185
		.307	Throw	9	10	11	12	13	14	14	16
			NC	<15	<15	<15	<15	19	23	27	33
24x24	14"	1.069	CFM	430	535	640	750	855	960	1070	1285
			Ps	.026	.041	.058	.080	.104	.131	.163	.234
		.418	Throw	11	12	13	14	15	16	17	18
			NC	<15	<15	<15	<15	18	23	28	35
24x24	15"	1.227	CFM	490	615	735	860	980	1105	1225	1475
			Ps	.032	.051	.072	.099	.129	.164	.201	.292
		.479	Throw	11	13	14	16	16	17	18	20
			NC	<15	<15	<15	16	22	27	31	39

**Performance Notes**

All Units have been tested in accordance with ANSI / ASHRAE 70-2006. Data in table is derived from such testing. Ps - Static pressure required to obtain listed cfm, units of inches water gauge (in. wg.).

NC - Calculated noise criteria using 10 dB per octave room attenuation (dimensional).

Throw - Non-isothermal horizontal throw, in feet, for a terminal velocity of 50 fpm. Ak - Area Factors

Inlet Velocity = fpm (Feet Per Minute)



ORDER CODE

S3CD	-	1	8"	RAL9010	T	24" X 24"
			inlet			
						Frame size Outsize
S3CD = 1						T: T-Bar Lay-in
S3CD-D = 2						
S3CD-R6 = 3						
S3CD-DR6 = 4						
6"						00: Without Coating
8"						
10"						
12"						
14"						RAL----: Powder Coating