



DESCRIPTION:

External weather louvers are externally mounted air transfer devices for the fresh air and exhaust air of air conditioning systems. They are installed in external walls and façades. Their narrowly arranged blades give good protection against the direct ingress of rain as well as against leaves and birds.

Under certain unfavourable conditions, such as heavy rain, and depending on the airflow velocity it might happen that slight quantities of water enter together with the air. This is why the airflow velocity in fresh air openings should not exceed 2,5 – 3 m/s.

CONSTRUCTION:

Standard Material Aluminum Optional: .304-316 Stainless Steel, Galvanized Sheet Steel.

APPLICATION:

- Maximum width of 2500 mm, maximum height of 2410 mm, maximum area of 4 m² (aluminium variant also for continuous horizontal runs)
- Low differential pressure due to aerofoil blades
- All aerodynamic data is measured in aerodynamics and acoustics laboratories

ACCESSORIES:

- Bird and insect screens
- Filters
- Dampers



STANDARD DIMENSIONS:

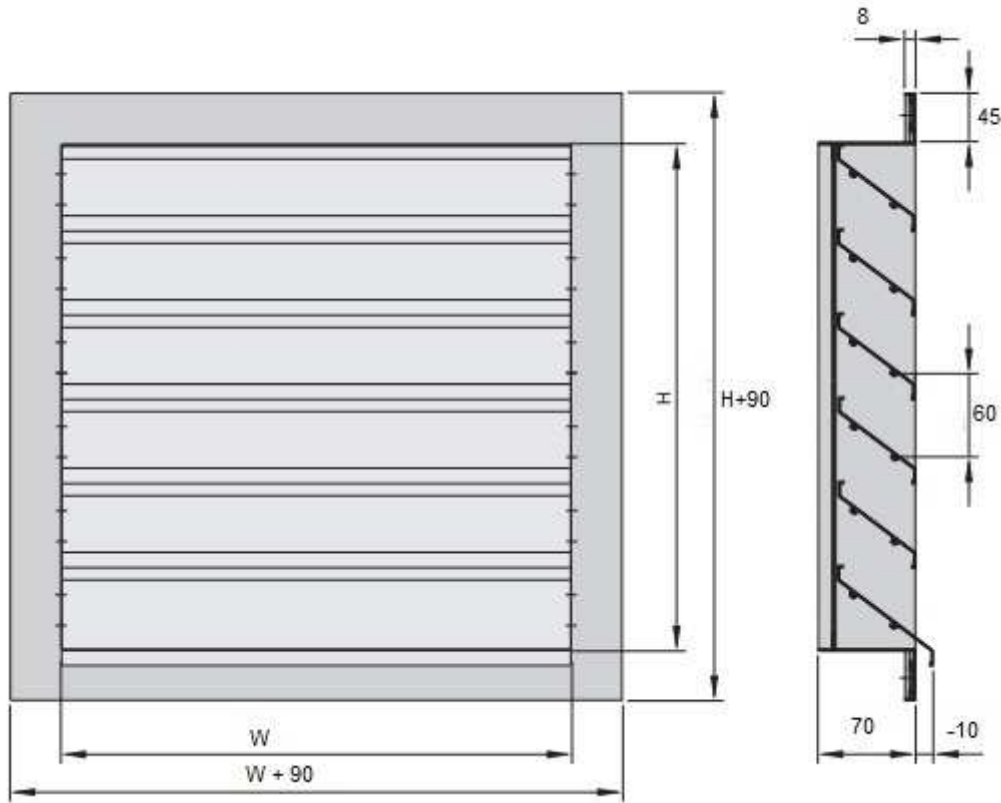

AVAILABLE SIZES (mm) - Always width x height														
HEIGHT	WIDHT													
	200	400	600	800	1000	1200	1400	1600	1800	2000	2200	2400	2900	3300
165	X	X	X	X	X	X	X	X	X	X	X	X	X	X
330	X	X	X	X	X	X	X	X	X	X	X	X	X	X
500	X	X	X	X	X	X	X	X	X	X	X	X	X	X
650	X	X	X	X	X	X	X	X	X	X	X	X	X	X
825	X	X	X	X	X	X	X	X	X	X	X	X	X	X
1000	X	X	X	X	X	X	X	X	X	X	X	X	X	X
1200	X	X	X	X	X	X	X	X	X	X	X	X	X	X
1350	X	X	X	X	X	X	X	X	X	X	X	X	X	X
1500	X	X	X	X	X	X	X	X	X	X	X	X	X	X
1650	X	X	X	X	X	X	X	X	X	X	X	X	X	X
1850	X	X	X	X	X	X	X	X	X	X	X	X	X	X
2000	X	X	X	X	X	X	X	X	X	X	X	X	X	X
2200	X	X	X	X	X	X	X	X	X	X	X	X	X	X
2300	X	X	X	X	X	X	X	X	X	X	X	X	X	X
2750	X	X	X	X	X	X	X	X	X	X	X	X	X	X
3100	X	X	X	X	X	X	X	X	X	X	X	X	X	X
3400	X	X	X	X	X	X	X	X	X	X	X	X	X	X
3750	X	X	X	X	X	X	X	X	X	X	X	X	X	X
4050	X	X	X	X	X	X	X	X	X	X	X	X	X	X
4400	X	X	X	X	X	X	X	X	X	X	X	X	X	X
4750	X	X	X	X	X	X	X	X	X	X	X	X	X	X



FUNCTIONAL DESCRIPTION

External weather louvers are externally mounted air transfer devices for the fresh air and exhaust air of air conditioning systems. They are installed in external walls and façades. Their narrowly arranged blades give good protection against the direct ingress of rain as well as against leaves and birds. Under certain unfavourable conditions, such as heavy rain, and depending on the airflow velocity it might happen that slight quantities of water enter together with the air. This is why the airflow velocity in fresh air openings should not exceed 2.5 – 3.0 m/s.

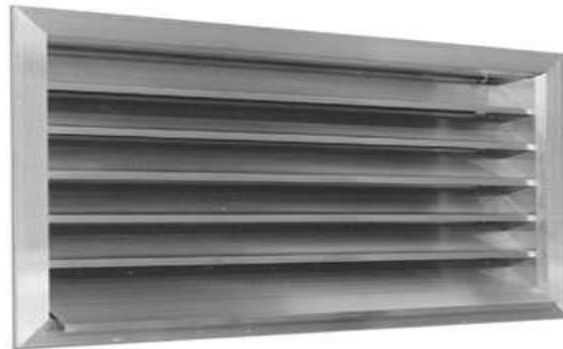

Schematic illustration of EXL361

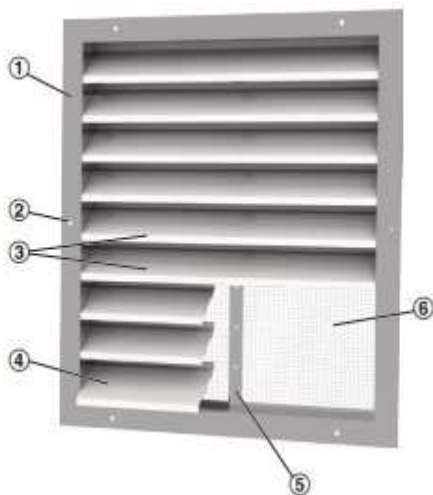

- ① Frame
- ② Fixing holes
- ③ Regular blades
- ④ Bottom blade
- ⑤ Stabilising mullion at the rear, from W = 1400
- ⑥ Wire mesh; additional insect screen as an option



- ① Frame
- ② Fixing holes
- ③ Regular blades
- ④ Bottom blade
- ⑤ Mullion from W= 1385
- ⑥ Wire mesh; additional insect screen as an option

EXL361- EXTERNAL WEATHER LOUVERS WITH LARGE BLADE



PERFORMANCE DATA

Nominal sizes	200x165 - 2500x1700 / 1700x2400
Width subdivided	Up to 5000 mm
Height subdivided	Up to 4800 mm
Horizontal runs (WG-B-AL)	H: 165 – 2000 mm
Volume flow rate range (undivided construction)	40 – 13350 l/s or 144 – 48660 m ³ /h at 2.5 m/s
Free area	Approx. 60 %, with insect screen approx. 45 %
Total differential pressure – exhaust air	30 Pa at 2.5 m/s
Total differential pressure – fresh air	35 Pa at 2.5 m/s

Quick Sizing

Height	Width [mm]											
	200		400		600		800		1000		1200	
mm	l/s	m ³ /h	l/s	m ³ /h	l/s	m ³ /h	l/s	m ³ /h	l/s	m ³ /h	l/s	m ³ /h
165	40	144	80	288	120	432	160	576	200	720	240	864
330	125	450	245	882	370	1332	490	1764	615	2214	735	2646
495	205	738	410	1476	615	2214	820	2952	1025	3690	1230	4428
660	290	1044	575	2070	865	3114	1150	4140	1440	5184	1725	6210
825	370	1332	740	2664	1110	3996	1480	5328	1850	6660	2220	7992
990	455	1638	905	3258	1360	4896	1810	6516	2265	8154	2715	9774
1155	535	1926	1070	3852	1605	5778	2140	7704	2675	9630	3210	11556
1320	620	2232	1235	4446	1855	6678	2470	8892	3090	11124	3705	13338
1485	700	2520	1400	5040	2100	7560	2800	10080	3500	12600	4200	15120
1650	785	2826	1565	5634	2350	8460	3130	11268	3915	14094	4695	16902
1815	865	3114	1730	6228	2595	9342	3460	12456	4325	15570	5190	18684
1980	950	3420	1895	6822	2845	10242	3790	13644	4740	17064	5690	20484
2145	1030	3708	2060	7416	3090	11124	4120	14832	5150	18540	6180	22248
2310	1115	4014	2225	8010	3340	12024	4450	16020	5560	20016	6680	24048
2740	1235	4446	2470	8892	3705	13338	4940	17784	6180	22248	7410	26676
3070	1400	5040	2800	10080	4200	15120	5600	20160	7000	25200	8400	30240
3400	1565	5634	3130	11268	4695	16902	6260	22536	7830	28188	9390	33804
3730	1730	6228	3460	12456	5190	18684	6920	24912	8650	31140	10380	37368
4060	1895	6822	3790	13644	5690	20484	7580	27288	9480	34128	11370	40932
4390	2060	7416	4120	14832	6180	22248	8240	29664	10300	37080	12360	44496
4720	2225	8010	4450	16020	6680	24048	8900	32040	11130	40068	13350	48060

Height	Width [mm]											
	1400		1600		1800		2000		2200		2400	
mm	l/s	m ³ /h	l/s	m ³ /h	l/s	m ³ /h	l/s	m ³ /h	l/s	m ³ /h	l/s	m ³ /h
165	280	1008	320	1152	360	1296	400	1440	440	1584	480	1728
330	860	3096	980	3528	1105	3978	1225	4410	1350	4860	1470	5292
495	1435	5166	1640	5904	1845	6642	2050	7380	2255	8118	2460	8856
660	2015	7254	2300	8280	2590	9324	2875	10350	3165	11394	3450	12420
825	2590	9324	2960	10656	3330	11988	3700	13320	4070	14652	4440	15984
990	3170	11412	3620	13032	4075	14670	4525	16290	4980	17928	5430	19548
1155	3745	13482	4280	15408	4815	17334	5350	19260	5890	21204	6420	23112
1320	4325	15570	4940	17784	5560	20016	6180	22248	6790	24444	7410	26676
1485	4900	17640	5600	20160	6300	22680	7000	25200	7700	27720	8400	30240
1650	5480	19728	6260	22536	7040	25344	7830	28188	8610	30996	9390	33804
1815	6060	21816	6920	24912	7790	28044	8650	31140	9520	34272	10380	37368
1980	6630	23868	7580	27288	8530	30708	9480	34128	10420	37512	11370	40932
2145	7210	25956	8240	29664	9270	33372	10300	37080	11330	40788	12360	44496
2310	7790	28044	8900	32040	10010	36036	11130	40068	12240	44064	13350	48060
2740	8650	31140	9880	35568	11120	40032	12350	44460	13590	48924	14820	53352
3070	9800	35280	11200	40320	12600	45360	14000	50400	15400	55440	16800	60480
3400	10960	39456	12520	45072	14090	50724	15650	56340	17220	61992	18780	67608
3730	12110	43596	13840	49824	15570	56052	17300	62280	19030	68508	20760	74736
4060	13270	47772	15160	54576	17060	61416	18950	68220	20850	75060	22740	81864
4390	14420	51912	16480	59328	18540	66744	20600	74160	22660	81576	24720	88992
4720	15580	56088	17800	64080	20030	72108	22250	80100	24480	88128	26700	96120

EXL361- EXTERNAL WEATHER LOUVERS WITH LARGE BLADE



Height	Width [mm]											
	2900		3300		3700		4100		4500		4900	
mm	l/s	m³/h	l/s	m³/h	l/s	m³/h	l/s	m³/h	l/s	m³/h	l/s	m³/h
165	560	2016	640	2304	720	2592	800	2880	880	3168	960	3456
330	1715	6174	1960	7056	2205	7938	2450	8820	2695	9702	2940	10584
495	2870	10332	3280	11808	3690	13284	4100	14760	4510	16236	4920	17712
660	4025	14490	4600	16560	5180	18648	5750	20700	6330	22788	6900	24840
825	5180	18648	5920	21312	6660	23976	7400	26640	8140	29304	8800	31968
990	6340	22824	7240	26064	8150	29340	9050	32580	9960	35856	10860	39096
1155	7490	26964	8560	30816	9630	34668	10700	38520	11770	42372	12840	46224
1320	8650	31140	9880	35568	11120	40032	12350	44460	13590	48924	14820	53352
1485	9800	35280	11200	40320	12600	45360	14000	50400	15400	55440	16800	60480
1650	10960	39456	12520	45072	14090	50724	15650	56340	17220	61992	18780	67608
1815	12110	43596	13840	49824	15570	56052	17300	62280	19030	68508	20750	74736
1980	13270	47772	15160	54576	17080	61416	18950	68220	20850	75060	22750	81864
2145	14420	51912	16480	59328	18540	66744	20600	74160	22660	81576	24700	88992
2310	15580	56088	17800	64080	20030	72108	22250	80100	24480	88128	26700	96120
2740	17290	62244	19760	71136	22230	80028	24700	88920	27170	97812	29650	106704
3070	19600	70560	22400	80640	25200	90720	28000	100800	30800	110880	33600	120960
3400	21910	78876	25040	90144	28170	101412	31300	112680	34430	123948	37550	135216
3730	24220	87192	27680	99648	31140	112104	34600	124560	38060	137016	41500	149472
4060	26530	95508	30320	109152	34110	122796	37900	136440	41690	150084	45500	163728
4390	28840	103824	32960	118656	37080	133488	41200	148320	45320	163152	49450	177984
4720	31150	112140	35600	128160	40050	144180	44500	160200	48950	176220	53400	192240

EFFECTIVE AREA

Metric System - m²

EXL-361 STANDARD SELECTION TABLE

		H (mm)												
Effective area (m ²)		250	300	350	400	500	600	800	1000	1200	1400	1600	1800	2000
W (mm)	300	0,0420	0,0540	0,660	0,0780	0,1050	0,1290	0,1800	0,2310	0,2820	0,3300	0,3810	0,4320	0,4830
	350	0,0490	0,0630	0,0770	0,0910	0,1225	0,1505	0,2100	0,2965	0,3290	0,3850	0,4445	0,5040	0,5635
	400	0,0560	0,0720	0,0880	0,1040	0,1400	0,1720	0,2400	0,3080	0,3760	0,4400	0,5080	0,5760	0,6440
	450	0,0630	0,0810	0,0990	0,1170	0,1575	0,1935	0,2700	0,3465	0,4230	0,4950	0,5715	0,6480	0,7245
	500	0,0700	0,0900	0,1100	0,1300	0,1750	0,2150	0,3000	0,3850	0,4700	0,5500	0,6350	0,7200	0,8050
	600	0,0840	0,1080	0,1320	0,1560	0,2100	0,2580	0,3600	0,4620	0,5640	0,6600	0,7620	0,8640	0,9660
	700	0,0980	0,1260	0,1540	0,1820	0,2450	0,3010	0,4200	0,5390	0,6580	0,7700	0,8890	1,0080	1,1270
	800	0,1120	0,1440	0,1760	0,2080	0,2800	0,3440	0,4800	0,6160	0,7520	0,8800	1,0160	1,1520	1,2880
	900	0,1260	0,1620	0,1980	0,2340	0,3150	0,3870	0,5400	0,6930	0,8460	0,9900	1,1430	1,2960	1,4490
	1000	0,1400	0,1800	0,2200	0,2600	0,3500	0,4300	0,6000	0,7700	0,9400	1,1000	1,2700	1,4400	1,6100
	1200	0,1680	0,2160	0,2640	0,3120	0,4200	0,5160	0,7200	0,9240	1,1280	1,3200	1,5240	1,7280	1,9320
	1400	0,1960	0,2520	0,3080	0,3640	0,4900	0,6020	0,8400	1,0780	1,3160	1,5400	1,7780	2,0160	2,2540
	1600	0,2240	0,2880	0,3520	0,4160	0,5600	0,6880	0,9600	1,2320	1,5040	1,7600	2,0320	2,3040	2,5760
	1800	0,2520	0,3240	0,3960	0,4680	0,6300	0,7740	1,0800	1,3860	1,6920	1,9800	2,2860	2,5920	2,8980
2000	0,2800	0,3600	0,4400	0,5200	0,7000	0,8600	1,2000	1,5400	1,8800	2,2000	2,5400	2,8800	3,2200	
2200	0,3080	0,3960	0,4840	0,5720	0,7700	0,9460	1,3200	1,6940	2,0680	2,4200	2,7940	3,1680	3,5420	

Note: Effective pressure areas for non standard size can be interpolated from the above data



Differential Pressure and Sound Power Level - metric

v	Installation type			
	C		D	
	Δp_t Pa	L_{WA} dB(A)	Δp_t Pa	L_{WA} dB(A)
m/s				
1.5	10	32	14	34
2	20	41	25	43
2.5	30	48	35	50
3	45	54	55	56
4	75	63	95	66
5	115	70	145	73
6	170	76	210	79

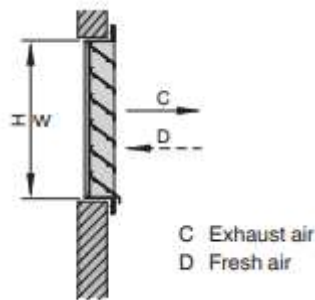

Sizing Example

Given data: Q =1400 l/s (5040 m³/h) ; V = 2.5 m/s

Fresh air, installation type D Maximum width: 800 mm

Quick sizing 800 x 825 mm

Calculation procedure

$$A = 0.800 \times (0.825 - 0.085) = 0.592 \text{ m}^2$$

$$V = Q/A = 1400/0.592 (\div 1000) = 2.4 \text{ m/s}$$

$$\Delta p_{st} = 35 \text{ Pa } L_{WA} = 50 \text{ dB(A)}$$

INSTALLATION DETAILS

Screw Mounting

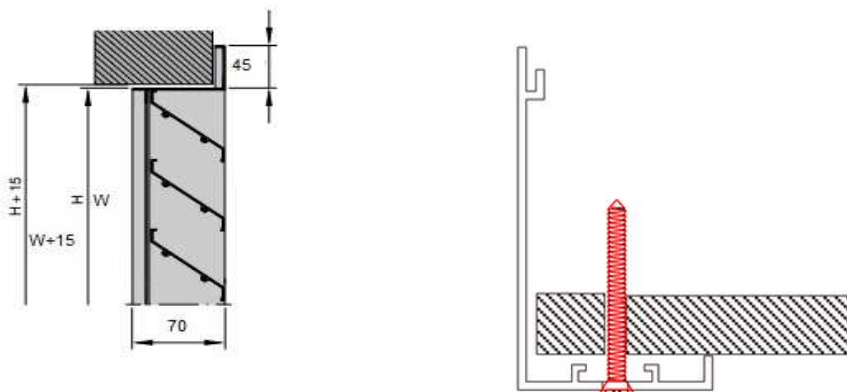

**EXL361- EXTERNAL WEATHER LOUVERS
WITH LARGE BLADE**



ORDER CODE

EXL-361	F45	00	RAL9010	SM	N 800X800
EXL-361: Z-Bladed				N: Neck Size F : Frame Size	
F45: Frame=45 mm				00: No Mounting SM: Screw Mounting	
00: No Wire Screen 01: Wire Screen Added				00: No coating EX: Eloxal Paint Coating RAL----: Oven Drying Paint Coating	